

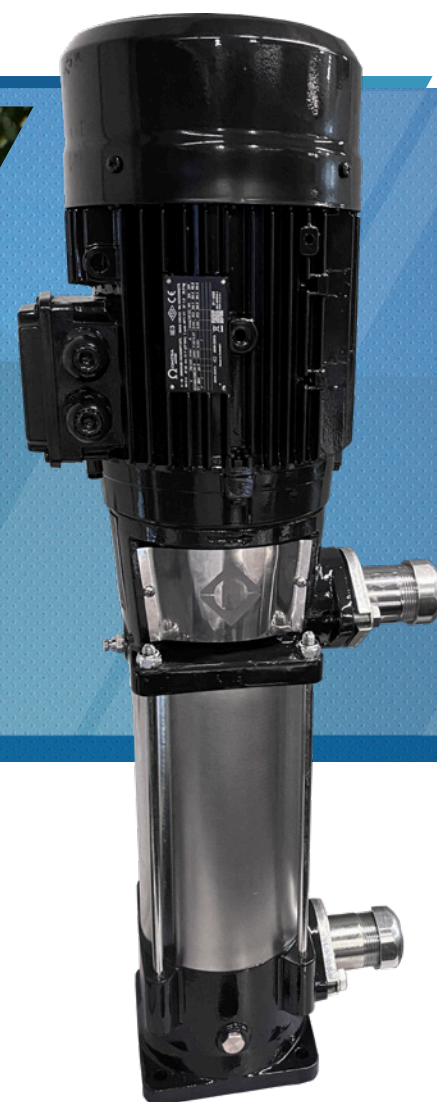

Franklin Electric

NCV SERIES 50 HZ

VERTICAL MULTISTAGE PUMPS



INDEX

NCV Series 50 Hz- Vertical multistage pumps	3
Family curves.....	4
General Features.....	4
Product identification code.....	5
Pump nameplate.....	6
Spare parts and materials	7
Motor specification	8
Motors Efficiency.....	8
Performance curves and technical data	9
ErP Regulation.....	10
Performance selection	11
4NCV	12
7NCV.....	14
10NCV.....	16
15NCV	18
Hydraulics connections	20

Franklin Electric S.r.l. reserves the right to amend specification without prior notice.
 For the most up-to-date product information, visit franklinwater.eu.



NCV Series 50 Hz- Vertical multistage pumps

- High-quality, efficient vertical multistage centrifugal pumps
- Compact design / according to ISO 9906
- High hydraulic performance / Reduced energy consumption
- Standardized connection with coupling between pump and motor
- Multiple mounting design for quick maintenance, including threaded counterflanges
- Noryl impellers and diffusers
- Easy installation parallel ports (Stainless steel counterflanges included in the package)
- Available in various model ranges (4NCV, 7NCV, 10NCV, 15NCV)

Technical data

- Motor Service Factor: 1,15
- Flow: up to 18 m³/h
- Head: up to 180 m
- Motor power: from 0.75 kW to 7.5 kW
- Maximum working pressure: PN25
- Liquid temperature range: 0°C / +40°C
- Three-phase asynchronous motors
- Insulation class: F
- Protection degree: IP55
- Maximum ambient temperature: 40°C

✓ **High efficiency hydraulic performance**

✓ **Robust and compact structure**

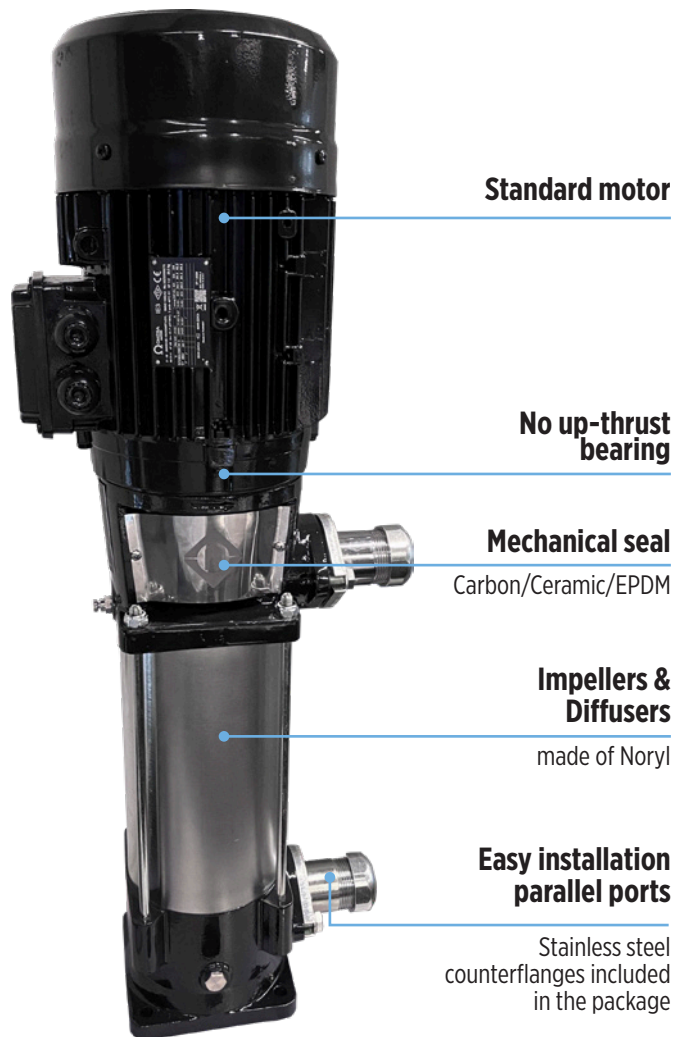

Stay up to date with the online version:



Water Distribution,
Pressure boosting,



Irrigation,
Water treatment plants,
Gardening, Sprinklers
Sprinklers



Domestic, industrial and
agricultural systems



Circulation of hot and cold
water for heating, cooling,
conditioning systems

NCV Series – Vertical multistage pumps

GENERAL FEATURES

Model		4	7	10	15
Rated flow [m ³ /h]		3,5	5	10	13
Maximum liquid temperature [°C]		40			
Application range [m ³ /h]		1,0 - 5,5	1,0 - 7,0	2,0 - 14,0	2,5 - 17,0
Max. pressure	Standard version	25	25	25	25
Motor power [kW] (2 poles)		0,75 - 1,5	1,1 - 3,0	2,2 - 5,5	2,2 - 7,5
Material versions	P (Cast-iron + Noryl)	•	•	•	•
Hydraulic connections (Dimensions)	Oval flange	•	•	•	•

“-” = not available

“•” = available

FAMILY CURVES

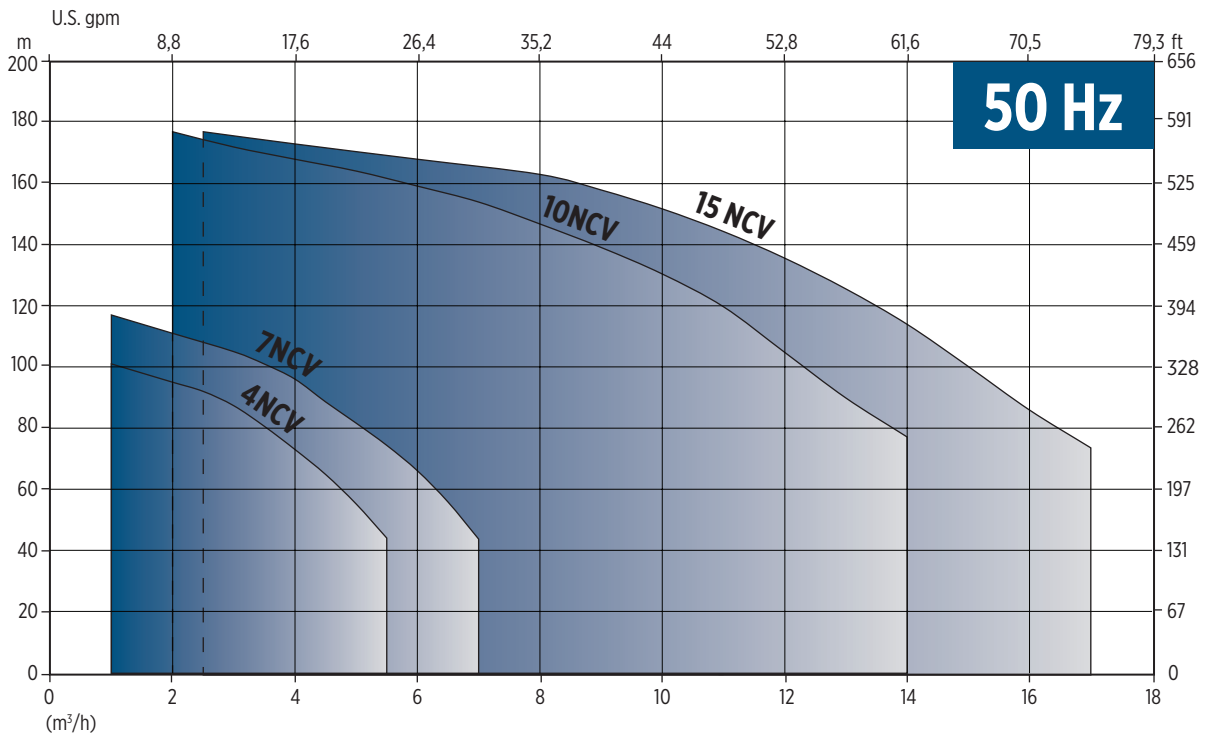

00F50057 12/2025

NCV Series – Vertical multistage pumps

PRODUCT IDENTIFICATION CODE



4 | NCV | 07 | X | - | P | S | - | T | 5 | 2 | B | 007 | - | BVE | - | PE

4	NCV	07	X	-	P	S	-	T	5	2	B	007	-	BVE	-	PE	Motor type	"PE" (pump end)	
																	Mechanical seal	"BVE" (Carbon/Ceramic/EPDM)	
																	Motor power [kWx10]		
																	Motor voltage	"0" (200V) "1" (115-230V) "2" (230V) "3" (380-415V) "4" (460V) "5" (575V) "6" (220V)	"8" (230-460V) "9" (415V) "A" (190-380V) "B" (230-400V) "C" (400-690V) "D" (220-380V)
																	No. of poles	"2" (2 poles)	
																	Frequency	"5" (50Hz, 3000rpm)	"6" (60Hz, 3600rpm)
																	Motor phase	"T" (Three-phase), "M" (Single-phase)	
																	Pump version	"S" (Standard version) "M" (Oversized motor)	
																	Material versions	"P" (Cast iron with Noryl impellers and diffusers)	
																	Trimmed impellers		
																	Number of stages		
																	Pump model		
																	Model No.		

001400191T_01/2020

NCV Series - Vertical multistage pumps

PUMP NAMEPLATE

		FRANKLIN ELECTRIC Srl	
		via Asolo 7	
		36031 Dueville (VI) - ITALY	
MODEL	A		
S/N°	B	Date	C
CODE	D		
Q	E	m ³ /h	H F m
Hmin	G	m	Hmax H m
MEI ≥	M	Hyd. Eff.	N %
Motor	L	Hz	P ₂ I kW
V _{nom.}	O	T _{amb}	P °C
A _{nom.}	R	Continuous Duty	
Motor	S	%	Cl T IP U
Weight	Q	kg	
Pmax/Tmax	V	bar/°C	
			
imported by Franklin Electric			

Ref. No.	Description
A	Model
B	Serial number
C	Year of production
D	Product code
E	Operating flow range
F	Operating head range
G	Minimum head
H	Maximum head
I	Maximum mechanical power absorbed by the pump
L	Motor frequency
M	Minimum efficiency index (MEI)
N	Maximum pump efficiency
O	Rated voltage
P	Ambient temperature
Q	Weight electric pump [kg]
R	Rated current
S	Motor efficiency class
T	Insulation and temperature class
U	Motor IP protection rating
V	Maximum operating pressure/Maximum temperature of the pumped liquid

Spare parts and materials

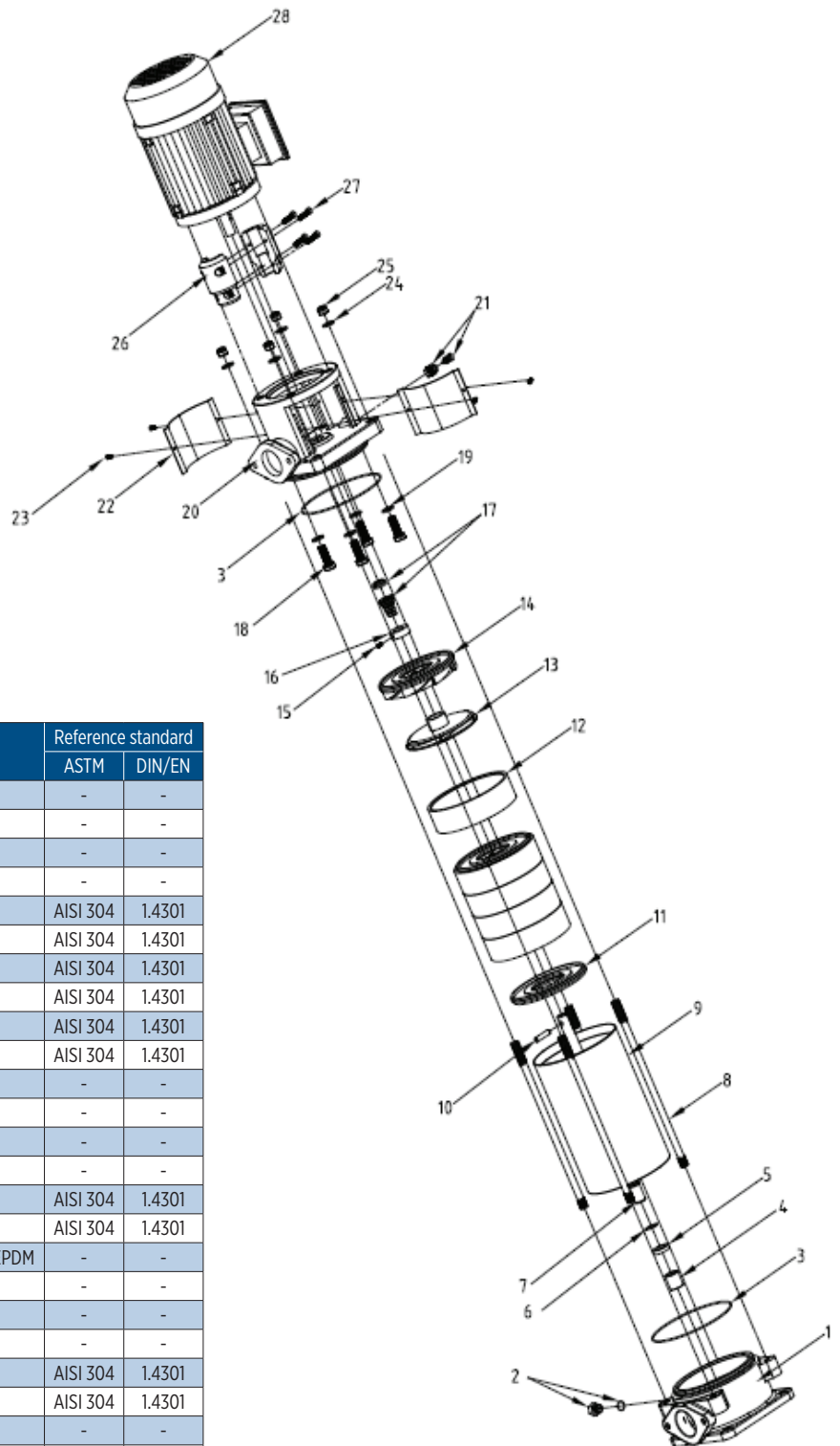

Ref. No.	Parts description	Material	Reference standard	
			ASTM	DIN/EN
1	Bottom casing	GG22-GG25	-	-
2	Plug	Brass	-	-
3	O-ring x 2	NBR	-	-
4	Intermediate bush bearing	Sinterized carbon	-	-
5	Retaining ring shaft	Stainless steel	AISI 304	1.4301
6	Retaining wire	Stainless steel	AISI 304	1.4301
7	Shaft	Stainless steel	AISI 304	1.4301
8	Tie rods	Stainless steel	AISI 304	1.4301
9	Outer casing	Stainless steel	AISI 304	1.4301
10	Shaft pin	Stainless steel	AISI 304	1.4301
11	Lower disc	Noryl	-	-
12	Diffuser casing	Noryl	-	-
13	Impeller	Noryl	-	-
14	Diffuser	Noryl	-	-
15	M4 bolt	Stainless steel	AISI 304	1.4301
16	Locking shaft	Stainless steel	AISI 304	1.4301
17	Mechanical seal	Carbon/ceramic/EPDM	-	-
18	M8x15 bolts	Galvanized steel	-	-
19	M8 washer	Galvanized steel	-	-
20	Upper casing	GG22-GG25	-	-
21	Upper casing plug	Stainless steel	AISI 304	1.4301
22	Coupling guard	Stainless steel	AISI 304	1.4301
23	M4x10 screws	Galvanized steel	-	-
24	M8 washer	Galvanized steel	-	-
25	M8 Teflon nut	Teflon	-	-
26	Coupling	Aluminum	-	-
27	M5x25 hexagon screws	Galvanized steel	-	-
28	Motor	Omega	-	-

Motors Efficiency

NEW INTERNATIONAL EFFICIENCY CLASSES OF MOTORS – IE CODE

IEC 60034-30:2008 defines the efficiency classes of motors worldwide.

IE1 = Standard Efficiency (comparable to EFF2)

IE2 = High Efficiency (comparable to EFF1)

IE3 = Premium Efficiency

The efficiency levels according to IEC 60034-30 are measured based on the test methods defined in IEC 60034-2-1:2007.

The IEC 60034-30 only defines requirements of efficiency classes and aims to create provisions for international consistency.

It does not define which motors must be supplied with which efficiency level. This is subject to respective regional legislation.

Output	IE2 code Standard Efficiency			IE3 code Standard Efficiency		
	2 poles	4 poles	6 poles	2 poles	4 poles	6 poles
0,37	69,5	72,7	67,6	73,8	77,3	73,5
0,55	74,1	77,1	73,1	77,8	80,8	77,2
0,75	-	-	-	80,7	82,5	78,9
1,1	-	-	-	82,7	84,1	81
1,5	-	-	-	84,2	85,3	82,5
2,2	-	-	-	85,9	86,7	84,3
3	-	-	-	87,1	87,7	85,6
4	-	-	-	88,1	88,6	86,8
5,5	-	-	-	89,2	89,6	88
7,5	-	-	-	90,1	90,4	89,1
11	-	-	-	91,2	91,4	90,3
15	-	-	-	91,9	92,1	91,2
18,5	-	-	-	92,4	92,6	91,7
22	-	-	-	92,7	93	92,2
30	-	-	-	93,3	93,6	92,9
37	-	-	-	93,7	93,9	93,3
45	-	-	-	94	94,2	93,7

Efficiency values according to IEC 60034-30:2008.

Efficiency standard calculation: IEC 60034-2-1:2007

Motor specification

Efficiency class	Motor Service Factor: 1,15													
	Power		IEC size	Design	I _n [A] 230 V	I _n [A] Y 400 V	I _n [A] Δ 400 V	I _n [A] Y 690 V	[min ⁻¹]	η %η %	cos φ	IA/IN	MA/MN	Weight [kg]
	[kW]	[HP]												
IE3	0,75	1	80	B14	3,13	1,8			2875	80,7	0,75	4,7	2,5	9
	1,1	1,5	80	B14	4,95	2,86			2865	82,7	0,77	4,8	2,4	10
	1,5	2	80	B14	6,78	3,91			2875	84,2	0,81	5,6	2,3	13
	2,2	3	90	B14	7,89	4,54			2885	85,9	0,82	5,8	2,4	16
	3	4	90	B14	10,7	6,18			2900	87,1	0,86	7	2,6	22
	4	5,5	100	B14			7,97	4,57	2905	88,1	0,87	7,3	2,6	26
	5,5	7,5	100	B14			9,9	5,74	2915	89,2	0,84	6,2	2,6	40
	7,5	10	100	B14			14	8,14	2915	90,1	0,86	6,4	2,6	46
	11	15	132	B14			19,8	11,5	2940	91,2	0,87	6,4	2,4	75

Performance curves and technical data

ErP Regulation

Information related to energy performance of the pump, according to Reg. 547/2012 CE:

Minimum efficiency index: $MEI \geq 0.7$;

The benchmark for most efficient water pumps is $MEI \geq 0,70$;

Year of manufacture: see nameplate or the label in the Instruction manual;

Manufacturer's name or trade mark, commercial registration number and place of manufacture: see nameplate or the label in the Instruction manual;

- 1) Product's type and size identificatory: see nameplate or the label in the Instruction manual;
- 2) Hydraulic pump efficiency with trimmed impeller: see nameplate or the label in the Instruction manual;
- 3) Pump performance curves for the pump, including efficiency characteristics: see technical datasheet (<http://franklinwater.eu/products/>);
- 4) The efficiency of a pump with a trimmed impeller is usually lower than that of a pump with the full impeller diameter. The trimming of the impeller will adapt the pump to a fixed duty point, leading to reduced energy consumption. The minimum efficiency index (MEI) is based on the full impeller diameter;
- 5) The operation of this water pump with variable duty points may be more efficient and economic when controlled, for example, by the use of a variable speed drive that matches the pump duty to the system;
- 6) Information relevant for disassembly, recycling or disposal at end-of-life: see the Instruction manual;
- 7) ---;
- 8) ---;
- 9) ---;
- 10) Information on benchmark efficiency is available at <http://europump.net/uploads/Fingerprints.pdf>;
- 11) Benchmark efficiency graph for $MEI = 0,7$ and for $MEI = 0,4$ available at: <http://europump.net/uploads/Fingerprints.pdf>;

Information related to energy performance of the motor, according to Reg. 2019/1781 CE and modifications:

- 1) Nominal efficiency (η) at the full, 75 % and 50 % rated load and voltage (UN): see motor nameplate or the Catalogue (<http://franklinwater.eu/products/>);
- 2) Efficiency level: see motor nameplate or the catalogue;
- 3) The year of manufacture: see motor nameplate;
- 4) Manufacturer's name or trade mark, commercial registration number and place of manufacturer: see the motor nameplate;
- 5) product's model number: see motor nameplate or the catalogue (<http://franklinwater.eu/products/>);
- 6) Number of poles of the motor: see motor nameplate or the catalogue (<http://franklinwater.eu/products/>);
- 7) The rated power output(s) or range of rated power output (kW): see motor nameplate or the catalogue (<http://franklinwater.eu/products/>);
- 8) The rated input frequency(s) of the motor (Hz): see motor nameplate or the catalogue (<http://franklinwater.eu/products/>);
- 9) The rated voltage(s) or range of rated voltage (V): see motor nameplate or the catalogue (<http://franklinwater.eu/products/>);
- 10) The rated speed(s) or range of rated speed (rpm): see motor nameplate or the catalogue (<http://franklinwater.eu/products/>);
- 11) Information relevant for disassembly, recycling or disposal at end-of-life: see the motor Instruction manual;
- 12) information on the range of operating conditions for which the motor is specifically designed (<http://franklinwater.eu/products/>):
 - a. altitudes above sea-level: 0-1000 m;
 - b. ambient air temperatures, including for motors with air cooling: max. 40°C;
 - c. ---;
 - d. maximum operating temperature: max. 60°C;
 - e. ---.

Performance selection

This section explains how to choose the pump model that best meets your needs.

The following information are required:

- Required flow
- Input and output pressure
- Fluid features: density, viscosity, temperature, chemical aggressiveness, and presence of abrasive particles.
- The connection type

Verify that the selected pump piping type can withstand the required maximum working pressure (pump nominal pressure $PN \geq$ application nominal pressure).

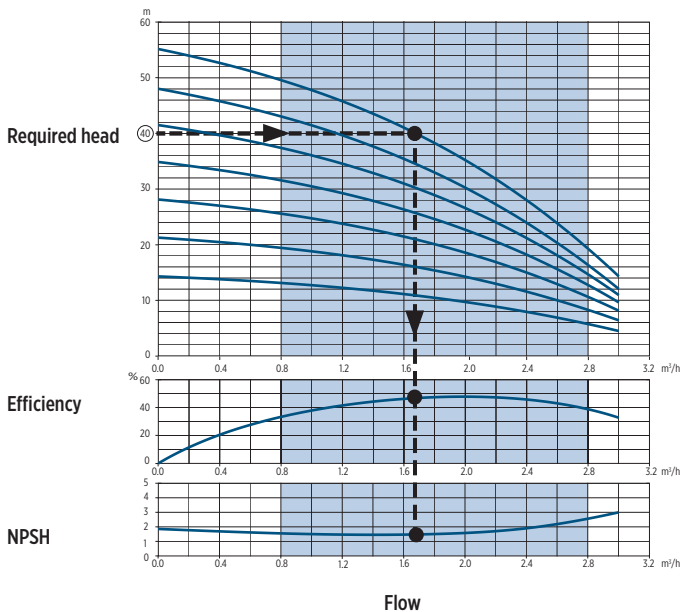

The difference between the required outlet pressure and the input pressure determines the head that the pump must supply to the fluid. The duty point is determined by crossing the flow and head values.

To ensure you get the best multistage pump, follow these steps:
Select the pump family according to the requested flow rate, choosing the one closest to the best efficiency point.

- 1) Choose the number of stages that is closest to the requested head.
- 2) Draw a vertical line from the duty point to determine the absorbed power, pump efficiency, and required NPSH.

If the viscosity of the fluid differs significantly from that of clean water at ambient temperature, it is necessary to adjust the selection parameters (contact the manufacturer). Additionally, if the density or viscosity is higher than that of water, a higher power sizing will be necessary (contact the manufacturer).

NPSH check:

Compare the available pump input NPSH value with the required pump value to avoid performance losses and pump wear.

The maximum height of the pump above the liquid level (H) can be calculated using this formula

$$H = pb \times 10.2 - NPSH - H_f - H_v - H_s$$

Where:

pb: Absolute barometric pressure or absolute pressure of the liquid on suction side [bar].

NPSH: Suction head at maximum duty flow rate [m]

H_f: Pressure drop in the suction pipe at maximum flow rate [m]

H_v: Vapour pressure [m] depending on the temperature of the liquid [m]

H_s: Safety margin [m] (minimum 0.5)

If the calculated value is less than 0, the pump must be positioned below the liquid level by the value of H.

Construction materials selection:

Select the mechanical seal and elastomers based on their compatibility with the pumped fluid and the presence of abrasive particles.

Similarly, pump materials (metal alloys) must be chosen according to the aggressiveness of the liquid. Liquid aggressivity usually increases with acidity or basicity, concentration of dissolved chlorides and salts, and working temperature.

Refer to the "Compatibility of Fluids and Materials" table on page 18 for the correct selection.

4NCV

HYDRAULIC PERFORMANCE 50 HZ

Pump model	Rated power		Q = Delivery											
			l/min 0	16,7	25	33	41,7	50	58,3	66,7	75	83,3	91,7	100
			m ³ /h 0	1	1,5	2	2,5	3	3,5	4	4,5	5	5,5	6
			US gpm 0	4,4	6,6	9	11	13	15,4	17,6	19,8	22	24,2	26
	[kW]	[HP]	H = Total meters head of water column [m]											
4NCV04-PS-T52B007-BVE	0,75	1	46,92	46	45	44	42	39	36	32	29	25	21	13
4NCV06-PS-T52B011-BVE	1,1	1,5	69,5	68	66	64	62	59	54	48,5	42,5	36,5	30	20
4NCV07-PS-T52B011-BVE	1,1	1,5	79	77,5	75	73	70	67	61	56	49	42	33	26
4NCV08-PS-T52B015-BVE	1,5	2	92,5	90	86	83	80	78	74	68	59	50	40	31
4NCV09-PS-T52B015-BVE	1,5	2	130,02	101	98	95	92	87	81	73	65	55	44	32

Application range

TECHNICAL DATA

Pump model	Rated power		Input current [A]	Inlet	Out	Dimensions [mm]										Weight [kg]
	[kW]	[HP]	400 V			A	B	C	D	E	H	H1	H2	F	G	
4NCV04-PS-T52B007-BVE	0,75	1	1,94	1 1/4"	1 1/4"	137	112	137	112	10	37	223	543	200	160	20
4NCV06-PS-T52B011-BVE	1,1	1,5	5									271	591			18
4NCV07-PS-T52B011-BVE	1,1	1,5	3									295	615			19
4NCV08-PS-T52B015-BVE	1,5	2	3,8									319	639			21
4NCV09-PS-T52B015-BVE	1,5	2	4									343	663			22

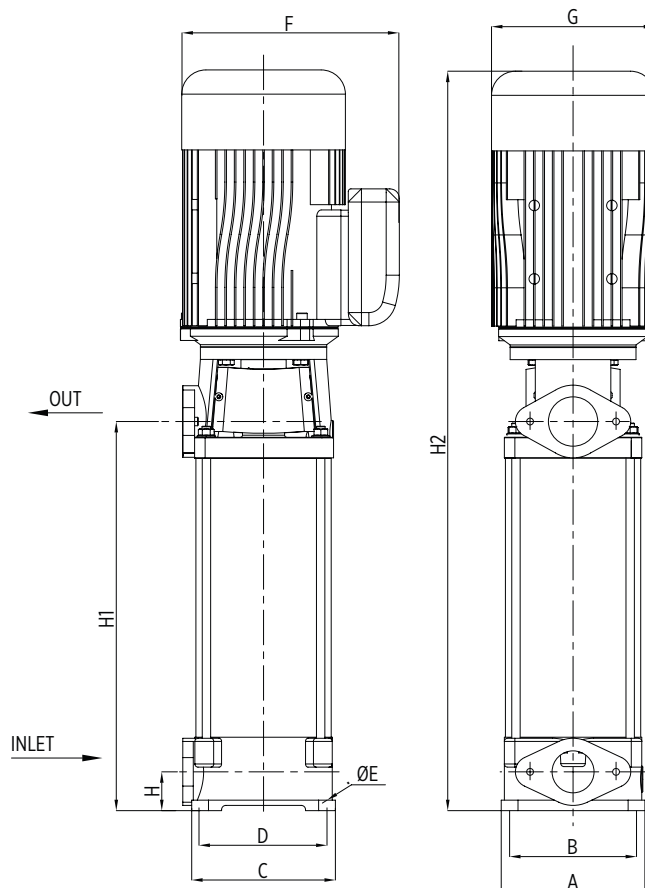

0030562.01/2026

4NCV - Performance curves at 50 Hz

MEI ≥ 0,40

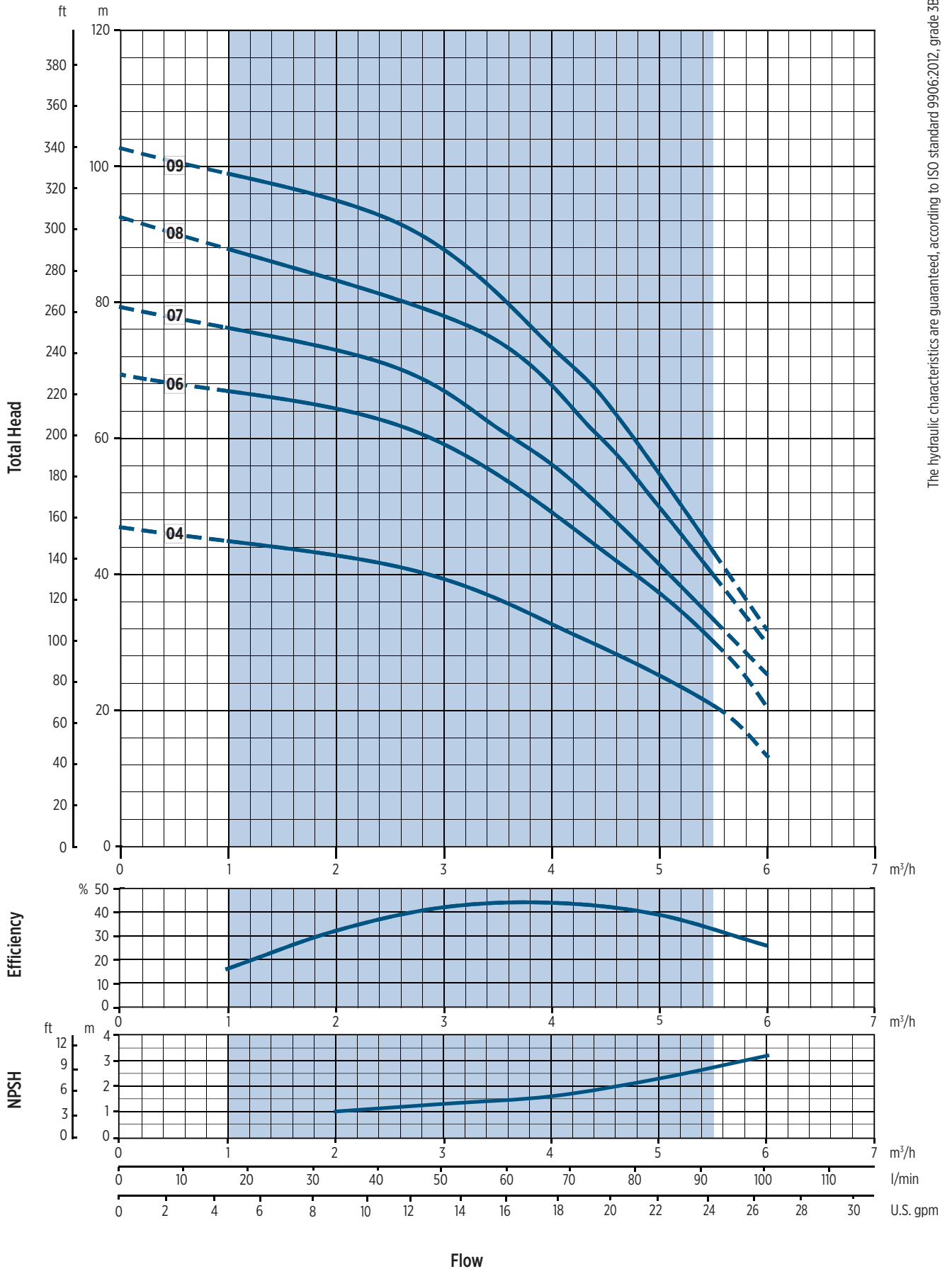

The hydraulic characteristics are guaranteed, according to ISO standard 9906:2012, grade 3B

7NCV

HYDRAULIC PERFORMANCE 50 HZ

Pump model	Rated power		Q = Delivery												
			l/min 0	16,7	33	50	58,3	66,7	75	83,3	91,7	100	108,3	116,7	125
			m ³ /h 0	1	2	3	3,5	4	4,5	5	5,5	6	6,5	7	7,5
	[kW]	[HP]	US gpm 0	4,4	9	13	15,4	17,6	19,8	22	24,2	26	28,6	30,8	33
			H = Total meters head of water column [m]												
7NCV06-PS-T52B011-BVE	1,1	1,5	69,36	67	64	60	56	52	48	42	38	33	26	18	9
7NCV07-PS-T52B015-BVE	1,5	2	82,11	79,5	75	71	68	64	59	53	48	41	36	26	14
7NCV08-PS-T52B022-BVE	2,2	3	92,82	90	84	80	77	74	69	62	55	47	39	30	16
7NCV09-PS-T52B030-BVE	3	4	107,1	105	101	96	92	86	80	75	68	60	50	39,5	28
7NCV10-PS-T52B030-BVE	3	4	120,5	117	111	105	101	96	89	82	74	66	56	44	31

Application range

TECHNICAL DATA

Pump model	Rated power		Input current [A] 400 V	Inlet	Out	Dimensions [mm]										Weight [kg]
	[kW]	[HP]				A	B	C	D	E	H	H1	H2	F	G	
7NCV06-PS-T52B011-BVE	1,1	1,5	3,1	1 1/4"	1 1/4"	137	112	137	112	10	37	271	591	200	160	18
7NCV07-PS-T52B015-BVE	1,5	2	3,9									295	615			20
7NCV08-PS-T52B022-BVE	2,2	3	4,7									319	684	24		
7NCV09-PS-T52B030-BVE	3	4	5,48									343	718	220	180	27
7NCV10-PS-T52B030-BVE	3	4	5,9									367	742	180	29	

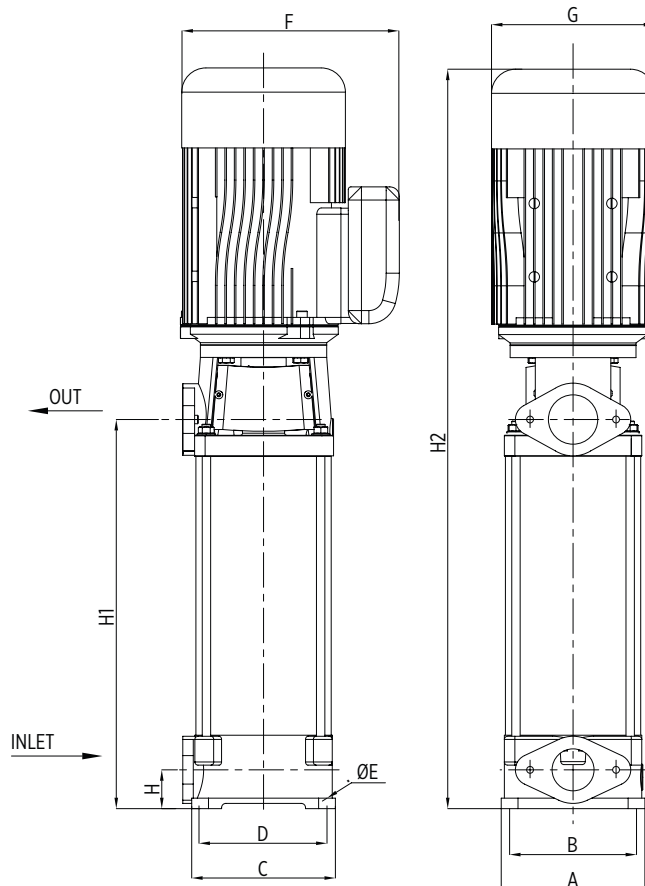

0030562.01/2026

7NCV - Performance curves at 50 Hz

MEI ≥ 0,40

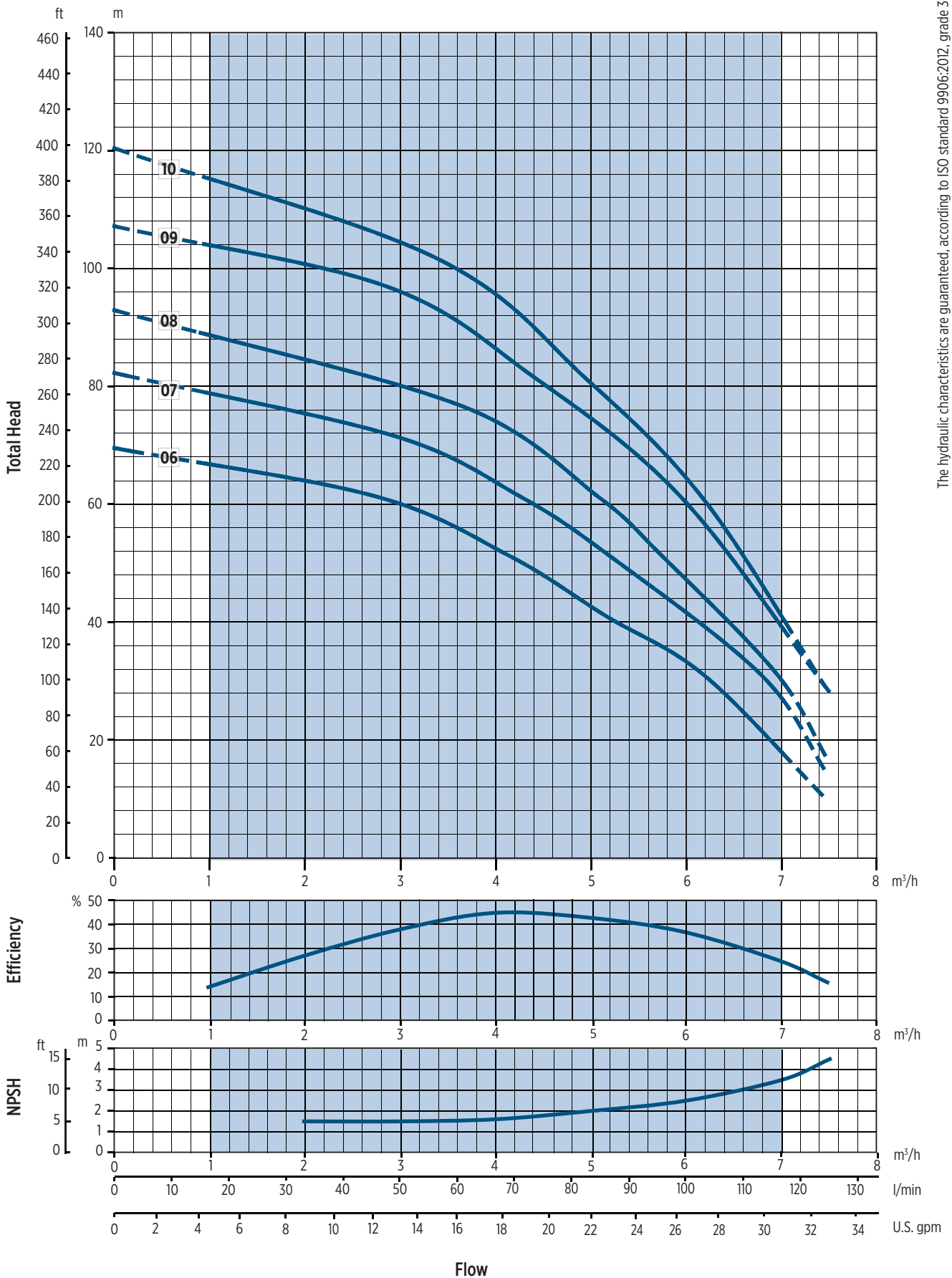

The hydraulic characteristics are guaranteed, according to ISO standard 9906:2012, grade 3B

10NCV

HYDRAULIC PERFORMANCE 50 HZ

Pump model	Rated power		Q = Delivery														
			l/min 0	33	50	66,7	83,3	100	116,7	133	150	167	183	200	217	233,3	250
			m ³ /h 0	2	3	4	5	6	7	8	9	10	11	12	13	14	15
	US gpm 0	9	13	17,6	22	26	30,8	35	40	44	48	53	57	61,6	66		
[kW]	[HP]	H = Total meters head of water column [m]															
10NCV05-PS-T52B022-BVE	2,2	3	79,5	75	72	70	67	64	61	58	54	50	44	38	31	22	12
10NCV07X-PS-T52B022-BVE	2,2	3	98,94	94	91	88	85	81	76	72	66	59	51	42	34	24,5	15
10NCV07-PS-T52B030-BVE	3	4	112,2	106	103	100	97	94	89	84	78	72	64	55	47	37	23
10NCV09-PS-T52B040-BVE	4	5,5	142,8	136	132	128	125	121	115	110	104	96	85	73	61	48	33
10NCV10-PS-T52B040-BVE	4	5,5	153	146	142	138	135	130	125	120	114	106	96	85	72	59,5	45
10NCV12-PS-T52C055-BVE	5,5	7,5	184,62	177	172	168	164	159	154	147	139	130	120	105	90	77	61

Application range

TECHNICAL DATA

Pump model	Rated power		Input current [A] 400 V	Inlet	Out	Dimensions [mm]										Weight [kg]	
	[KW]	[HP]				A	B	C	D	E	H	H1	H2	F	G		
10NCV05-PS-T52B022-BVE	2,2	3	5,15	1 1/2"	1 1/4"	153	122	153	122	12	38	322	696	220	180	22	
10NCV07X-PS-T52B022-BVE	2,2	3	5,98									398	772				
10NCV07-PS-T52B030-BVE	3	4	6,89									398	772				
10NCV09-PS-T52B040-BVE	4	5,5	8,4									482	883	230	200		40
10NCV10-PS-T52B040-BVE	4	5,5	9,58									520	920				
10NCV12-PS-T52C055-BVE	5,5	7,5	11,8									596	1020	260	220		

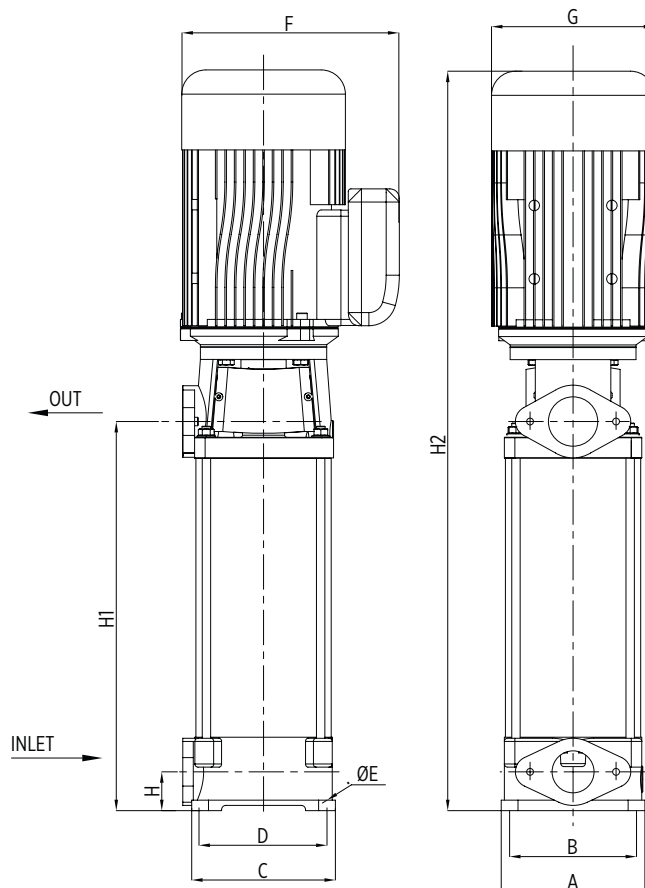

0030562.01/2026

10NCV - Performance curves at 50 Hz

MEI ≥ 0,40

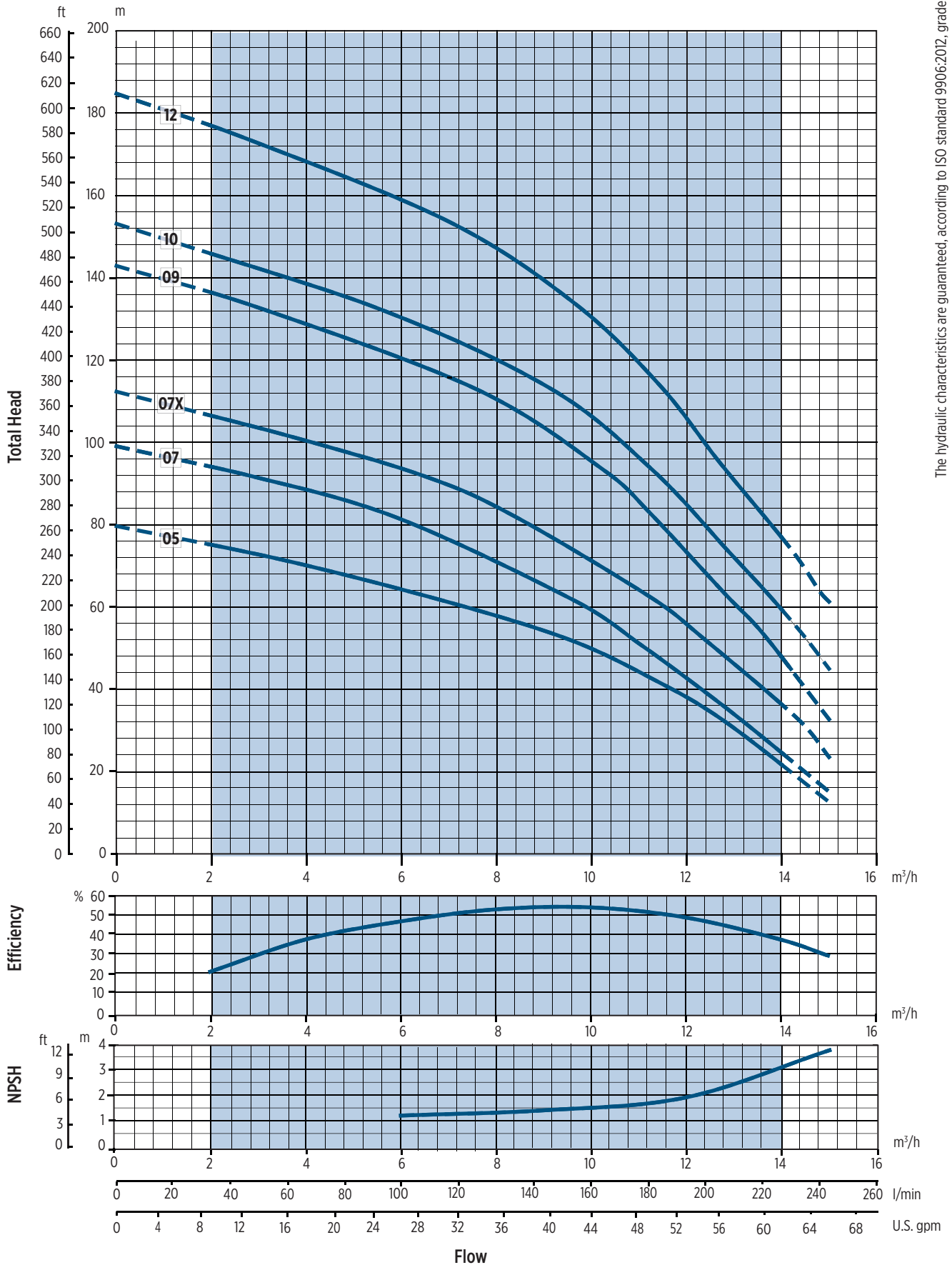

The hydraulic characteristics are guaranteed, according to ISO standard 9906:2012, grade 3B

15NCV

HYDRAULIC PERFORMANCE 50 HZ

Pump model	Rated power		Q = Delivery														
			l/min 0	41,7	66,7	100	133	150	167	183	200	217	233,3	250	267	283	300
	m ³ /h 0	2,5	4	6	8	9	10	11	12	13	14	15	16	17	18		
	US gpm 0	11	17,6	26	35	40	44	48	53	57	61,6	66	70	75	79		
[kW] [HP]		H = Total meters head of water column [m]															
15NCV04-PS-T52B022-BVE	2,2	3	61,2	60	57	57	54	52	51	48	45	41	37	33	29	21	10
15NCV05-PS-T52B030-BVE	3	4	76,5	75	73	70	67	65	62	59	56	52	47	42	36	26	14
15NCV06-PS-T52B040-BVE	4	5,5	92,82	91	88	87	82	80	77	73	68	63	56	50	43	36	20
15NCV07-PS-T52B040-BVE	4	5,5	107,1	106	101	98	95	93	90	84	78	72	65	58	50	42	23
15NCV08-PS-T52C055-BVE	5,5	7,5	122,5	121	118	114	111	107	103	98	93	88	81	73	65	56	45
15NCV09-PS-T52C055-BVE	5,5	7,5	138,72	138	132	129	126	124	120	114	108	101	93	85	74	62,5	51
15NCV12-PS-T52C075-BVE	7,5	10	178,5	177	173	168	163	158	152	144	136	126	114	100	86	73,5	56

Application range

TECHNICAL DATA

Pump model	Rated power		Input current [A] 400 V	Inlet	Out	Dimensions [mm]										Weight [kg]
	[kW]	[HP]				A	B	C	D	E	H	H1	H2	F	G	
15NCV04-PS-T52B022-BVE	2,2	3	5,35	1 1/2"	1 1/2"	153	122	153	122	12	38	285	658	220	180	21
15NCV05-PS-T52B030-BVE	3	4	6,4									322	696			31
15NCV06-PS-T52B040-BVE	4	5,5	7,6									367	777			36
15NCV07-PS-T52B040-BVE	4	5,5	8,5									402	815	230	200	37
15NCV08-PS-T52C055-BVE	5,5	7,5	10,3									443	873	260	220	43
15NCV09-PS-T52C055-BVE	5,5	7,5	11,2									482	910			44
15NCV12-PS-T52C075-BVE	7,5	10	14									596	1020			54

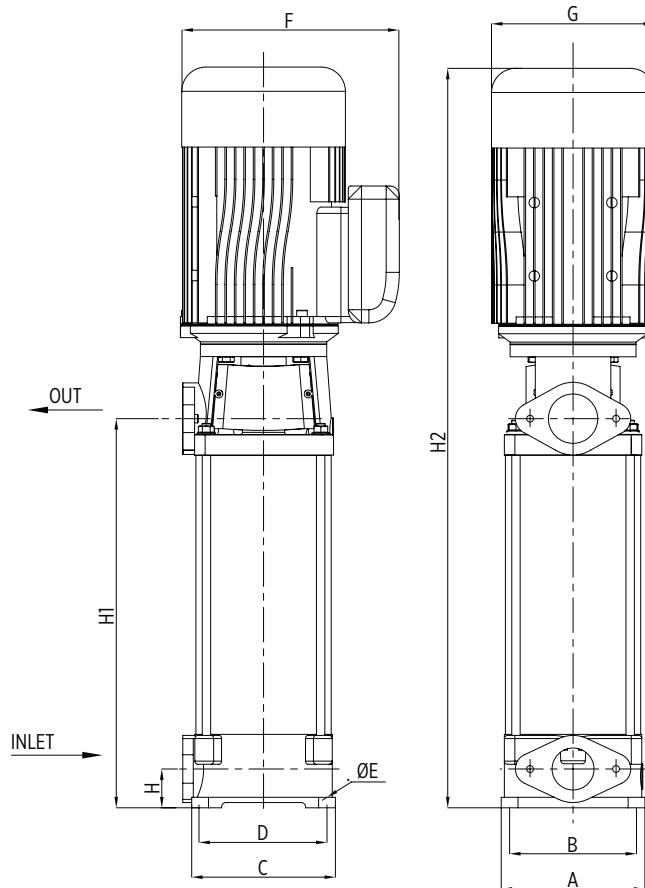

00130362 01/2016

15NCV - Performance curves at 50 Hz

MEI ≥ 0,40

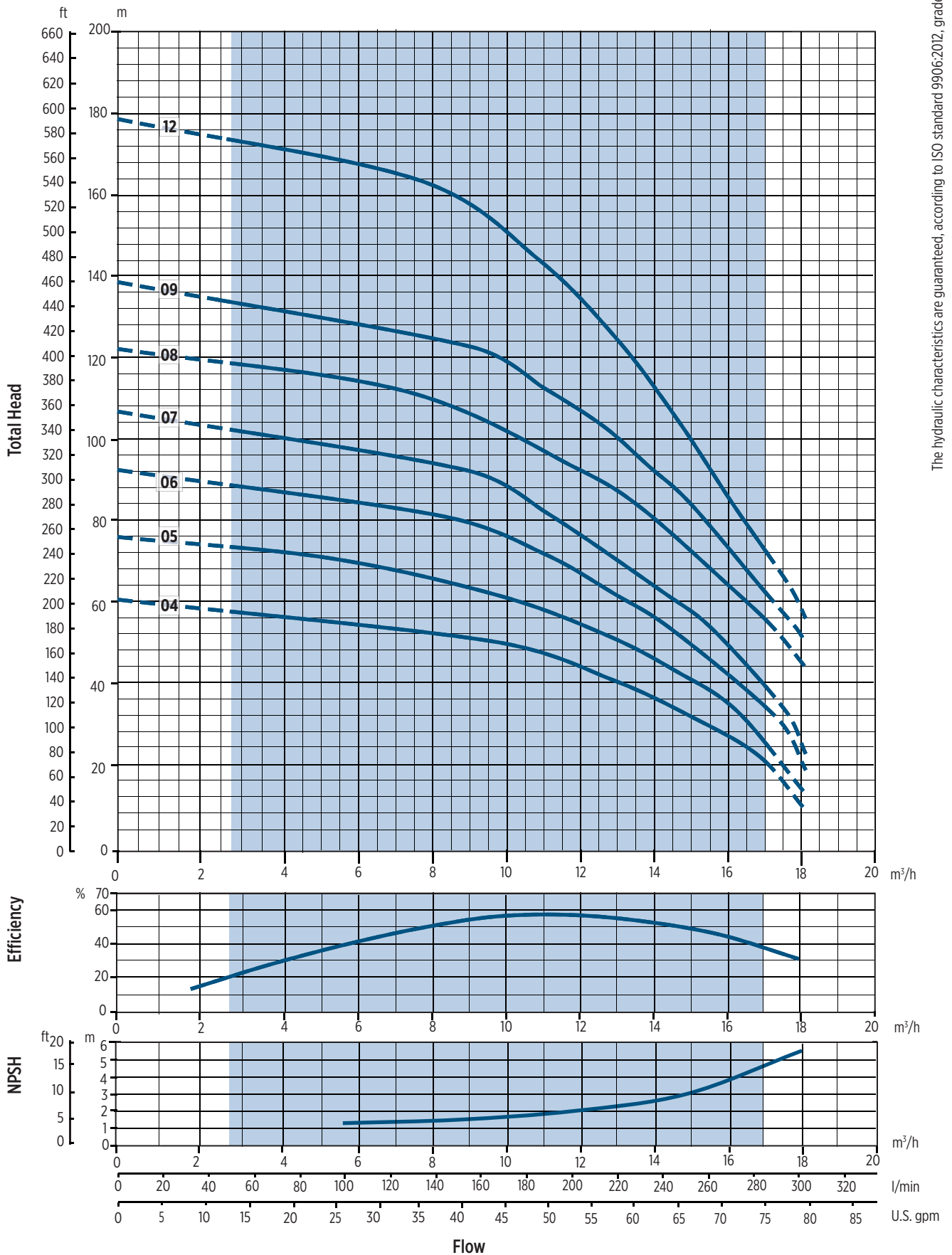

The hydraulic characteristics are guaranteed, according to ISO standard 9906:2012, grade 3B

Hydraulics connections

Pump model	Dimensions [mm]									
	Inlet					Out				
	N	O	K	L	M	N	O	K	L	M
4NCV	40	64	82	110	M8	40	64	86	110	M8
7NCV						42	68	88	117	
10NCV	42	68	88	110	M8	42	68	88	117	M8
15NCV						42	68	88	117	

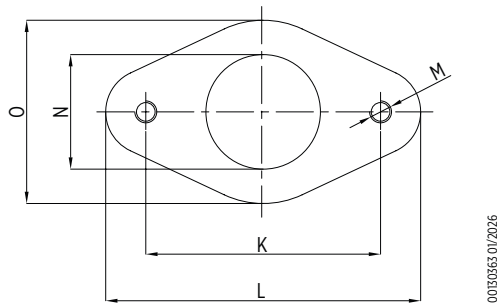

00150565 01/2026

CATALOG REVISION CHANGES NOTICE

Rev. No.	Changes	Page
01	"Technical Data" description - updated	3
	"Motor Specifications" table - updated	8
	"Technical Data" tables - "Input current [A] 400V" column added	12, 14, 16, 18
	"Performance Curves" graphs - NPSH and Efficiency graphs added; Power P ₂ graph removed	13, 15, 17, 19



Franklin Electric

Franklin Electric Europa GmbH
Rudolf-Diesel-Str. 20 - 54516 Wittlich
GERMANY
Phone: +49 (0) 6571 - 105-0
Fax: +49 (0) 6571 - 105-510
Email: info@franklin-electric.de

Franklin Electric S.r.l.
Via Asolo, 7 - 36031 Dueville (Vicenza)
ITALY
Phone: +39 0444 361114
Fax: +39 0444 365247
Email: sales.it@fele.com



1000026488 EN REV.01_04-2026



franklinwater.eu

Single member - Company subject to the control and coordination of Franklin Electric Co., Inc.
Franklin Electric reserves the right to amend specification without prior notice.