

6", 8", 10" and 12" Rewindable Submersible Motors

GB

Assembly and Operating Instructions

1 About This Document	2
1.1 Warning notices and warning symbols	2
1.2 Instructions and Highlights	2
2 Safety	3
2.1 Intended use	3
2.2 Target group	3
2.3 General safety instructions	3
3 Storage, Transport, Disposal	4
4 Technical specifications	4
5 Pre-Operation Checks	6
5.1 Check the motor prior to installation	6
5.2 Assembling the motor and pump	8
5.3 Connecting the drop cable	8
5.4 Measuring the insulation resistance	9
5.5 Powering the motor	9
6 Motor Operation	11
6.1 Proper motor cooling	11
6.2 Providing a check valve and level sensor	11
6.3 Switching on the motor	11
6.4 Motor operation with frequency converter	11
6.5 Motor operation with softstarter	12
6.6 PT100 Trip point	12
7 Maintenance and service	12
8 Troubleshooting	12
9 Service	12
10 Appendix	12



Franklin Electric Europa GmbH Rudolf-Diesel-Straße 20
D-54616 Wittlich, Germany
Tel.: +49 (0) 65 71 / 105 - 0
Fax: +49 (0) 65 71 / 105 - 520

E-Mail: field-service@franklin-electric.de Internet:
www.franklinwater.eu

Doc.-no.: 308 018 427
Version: March 2026



© Copyright by Franklin Electric 2022

All rights on these instructions – particularly the right to reproduce, distribute and translate – are reserved. No part of the instructions is allowed to be reproduced in any form (by printing, photocopy, microfilm, or another method) without the prior written authorization by the company Franklin Electric or may not be processed, reproduced or distributed by use of electronic systems.

We reserve the right to make changes due to technical progress

Declaration of Conformity for Franklin Electric Submersible Motors:

download the Declaration of conformity in your Language under: <https://franklinwater.eu/more/legal-documents/doc-declaration-of-conformity-products/>



1 About This Document

The assembly and operating instructions form an integral part of the rewindable submersible motor and describe its safe, intended use in all operating phases.

- Document Retention** ⇒ Keep the assembly and operating instructions in the immediate vicinity of the motor.
⇒ Hand the assembly and operating instructions over to every subsequent user of the motor.

Application The assembly and operating instructions only apply to the motors described in this booklet.

1.1 Warning notices and warning symbols

Warning notices point out special dangers and indicate the measures that can be taken to avoid the danger. Warning notices come in three levels:

Warning word	Meaning
DANGER	Immediate danger to life and health
WARNING	Possible danger to life and health
CAUTION	Possible danger of slight injury or material damage

Warning notices are built up as follows:



Warning word

Type and source of danger as well as the possible consequences of measures not being observed!

⊙ *Forbidden actions.*

⇒ *Measures to avoid the danger.*

1.2 Instructions and Highlights

In the assembly and operating instructions we use the following symbols and highlights, for improved legibility and uniform identification.

- Insulation measuring unit (this indicates a listing)
☑ Instructions ... observed (this indicates a condition)
⇒ Switch off the motor. (this indicates an instruction to take action)
Motor has stopped. (this indicates the result of the action)
Immediately switch off the (you can see a highlight in bold here)
motor...



Note

Specifically, important information is given here. You should observe this information to ensure correct and safe operation of the motor.

2 Safety

This section describes the safety rules which must be observed for the safe use of submersible motors. Possible sources of danger and the relevant safety measures are listed here.

2.1 Intended use

Franklin Electric submersible motors are only intended for integration with a submersible pump in order to drive the relevant pump under water. They must only be put into use if the machine fulfils the provisions of the applicable directives and statutory provisions.

Installation position: Vertical (Mandatory mounting position: vertical, shaft up. Only one diameter step allowed, i.e. 6" motor on 8" pump). Horizontal (only allowed if the pump size is identical to the motor size, e.g. 6" motor with 6" pump). The pump has to sufficient "Down Thrust" transmit to the motor.

The submersible motors must only be used in clean, highly fluid media, such as drinking or process water.

The following media are not allowed: air, highly flammable, explosive media and wastewater.

Loss of guarantee and exclusion of liability

Franklin Electric shall not be liable for the damage resulting from any further, non-intended use. The risk of such use rests solely with the user.

2.2 Target group

The electrical system must only be installed by professional staff (qualified electrical engineers or electrical machine technicians).

2.3 General safety instructions

The following safety measures must be observed prior to putting the motor into use:

- Do not carry out any other work on the motor other than described in these instructions.
- Only use the motor under water (the motor and the short motor cable must be fully submersed).
- Do not implement any changes or conversions to the motor or its electrical connections.
- Never open the motor.
- Never use the motor in combination with damaged pump units or parts.
- Only work on the motor when it is switched off. No work or checks require the motor to be running.
- Switch off the power supply to the motor before carrying out any work on it.
- Make sure that nobody can switch on the voltage unexpectedly while work is being carried out on the motor.
- Never work on electrical systems during a thunderstorm.
- Make sure immediately after ending the work that all protective and safety devices have been fitted again and are operational.
- Before switching on the motor, make sure that all electrical connections and safety devices have been checked and that all fuses and safeties have been set correctly.
- Make sure that no danger zones are freely accessible (e.g. rotating parts, suction locations, pressure output locations, electrical connections).
- Observe the pump manufacturer's commissioning instructions.
- If motors or pump units have been used in contaminated media, they must be marked as such before handing them over to a third party (e.g. when submitting them for repair). Pay attention to possible residues in "dead spaces" (diaphragm cover).
- Contaminated motors or pump units must be marked as such before handing them over to a third party (e.g. when submitting them for repair).
- Repairs must only be carried out by authorized professional workshops. Use only original Franklin Electric spare parts.

3 Storage, Transport, Disposal

- Storage**
- ⇒ Store the motor in its original packaging until the time of installing it.
 - ⇒ If the motor is stored standing up, make sure that it cannot topple over (shaft always pointing up!).
 - ⇒ Do not store the motor in direct sunlight or within the reach of other heat sources.
 - ⇒ Observe the storage temperature (-15 - +60°C, see technical specifications).

Transport



DANGER

Falling loads may cause lethal injuries or may crush parts of the body!

- ⊙ Nobody is allowed to be located under suspended loads.
 - ⇒ Only use approved hoisting gear.
 - ⇒ Select the hoisting gear on the basis of the total weight to be transported.
-

Unpacking

- ⇒ After unpacking the motor check it for possible damage, e.g. damage to the diaphragm cover, housing, end bell, connection and motor cable.
- ⇒ Immediately inform the supplier of any damage found.



DANGER

Danger to life due to electrocution if the motor cable is damaged!

- ⊙ Do **not** install the motor and do **not** put it into operation.
-

Disposal

In order to avoid environmental damage:

- Avoid contamination by lubricants, detergents etc.
- Dispose of the motor and the packaging material in a proper, environmentally sound manner.
- Observe local regulations.

4 Technical specifications

Description	Value
Performance/model number	6": 4 - 37 kW models 262 ... 8": 30 - 93 kW models 263 ... 10": 85 - 185 kW models 264 ... 12": 185 - 400 kW models 265 ...
Winding insulation	Standard: PPC Optional: PE2/PA (12 inch Standard)
Standard Voltage range	220 V ... 1000 V, 3~ 50/60/100/120 Hz
Voltage tolerance (on the motor terminals)	50Hz: -10 to +6 % of U_N , i.e. at a nominal voltage of 380-415 V: 380 V -10 % = 342 V / 415 V + 6 % = 440 V 60Hz/100Hz/120Hz: ± 10% of U_N
Frequency tolerance	± 2%
Speed	approx. 2900 rpm at 50 Hz & 3450 rpm at 60 Hz, 100 Hz approx.. 3000 rpm, 120 Hz approx. 3600 rpm
Start alternatives	Direct starting, wye-delta-starting

Description	Value
Switching frequency	Max. number of switching actions per hour with a minimum off time of 90 seconds 6": 20 switching actions 8", 10": 10 switching actions 12": 5 switching actions
Protection	IP 68 according to IEC 60529
Submersion depth	max. 350 m
Installation location	Vertical (Mandatory mounting position: vertical, shaft up. Only one diameter step allowed, i.e. 6" motor on 8" pump). Horizontal (only allowed if the pump size is identical to the motor size, e.g. 6" motor with 6" pump). The pump has to sufficient "Down Thrust" transmit to the motor. 6"–37 kW, 8"– 83/93 kW , 10" PM 250 kW can not be used horizontally (if required please contact Franklin Electric) . No general guarantee when installed in pressure boosting systems
Operating temperature	≥ -3 °C
Sound pressure level	≤ 70 dB(A)
Maximum axial thrust towards the motor (8" and 10" motors: for clockwise rotation please consult Franklin Electric)	6": 4 - 26 kW 15.5 kN 30 - 37 kW 27.5 kN 8": all motors 45.0 kN 10": all motors 60.0 kN 12": all motors 60.0 kN (Optional 80 kN)
Maximum axial thrust away from the motor (only for a short-time load of max. 3 minutes; independent of performance rating)	6": 2.0 kN 8" 3.0 kN 10" / 12": 4.4 kN
Material	The person placing the order is responsible for selecting the correct material, specifically as regards its resistance in the medium to be transported. Cast-Iron Design: Stator 304, powder-coated castings 304SS: Stator and castings (only 6") 316SS: Stator and castings 904L: Stator and castings
Motor fluid	FES 93 (approved, water-based emulsion) Filling fluid replacement on request
Weight	Technical data sheets (see appendix)
Storage temperature	-15 °C to +60 °C
Motor cable	KTW and VDE short motor cables are included in the delivery. 6": Motor cable 4.0 m long 8", 10" & 12": Motor cable 6.0 m long
Connection flange	6", 8": NEMA flange (see appendix) 10" & 12": Standard flange (see appendix)
Temperature monitoring	PT100 temperature sensor for retrofitting (separate order; see appendix)

Motor cooling

Motor size (")	Performance rating (kW)	Coolant flow speed* (m/s)	Max. medium temperature for winding (°C)
6	5.5 - 15	0.2	50
	18.5 - 30	0.5	50
	37	0.5	45
8	30 - 52	0.2	50
	55 - 93	0.5	50
10	85 - 185	0.5	45
12	185 - 400	0,5	30

*The **coolant flow speed** is the speed of the medium flowing along the motor casing during normal operation.

In the event of higher media temperatures, operation is only allowed if you

- reduce the performance (De-Rating, see Appendix),
- increase the coolant flow speed.

5 Pre-Operation Checks

5.1 Check the motor prior to installation

If a leak is visible or if the motor is more than one year old (e.g. in the event of re-use or after long storage):

⇒ Check the fluid level in the motor prior to installing it.

Tools You need the following tools for assembly and inspection work:

- Insulation measuring unit: 500 VDC testing
 - Filling Kit 308 726 103
- ⇒ Determine the age of the motor by checking manufacturing code near the type plate (see Figure 5-1).

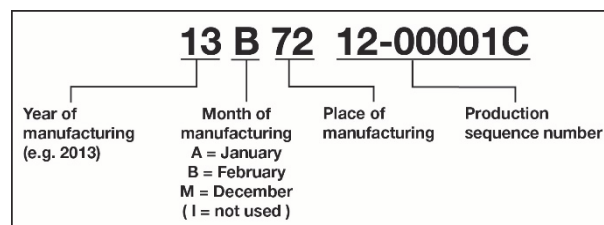

Figure 5-1: manufacturing code with date and place of manufacture

5.1.1 Checking the motor fluid



CAUTION

Motor damage due to being insufficiently filled!

- ⇒ Fill the motor with sufficient motor fluid
- ⇒ Wear safety goggles and gloves when filling and draining the motor.

⇒ Top up using original motor fluid from Franklin Electric FES93 (concentrate FES92 id. no. 308 353 941, 5-liter container) or clean drinking water.
Never use distilled water!

Filling volumes

- 6": approx. 5 litres
- 8": approx. 12 litres
- 10": approx. 20 litres
- 12": approx. 41 liters

Venting the motor

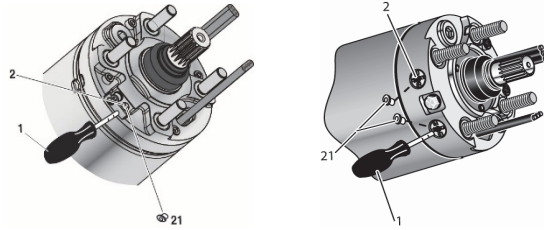

Figure 5-2: 6", 8", 10" motor

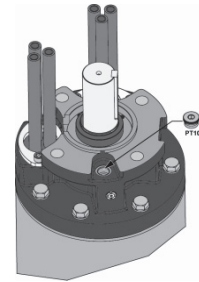
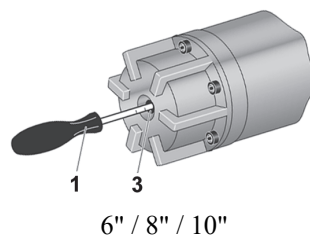

Figure 5-3: 12" motors

- ⇒ Place the motor horizontally so that the filling valve (2) is located at the highest position.
- ⇒ Remove the plug (21) from the filling valve (2).
- ⇒ Carefully push the test pin (1) into the filling valve (2) until air and some fluid escape from it.

Checking the motor 6-12"



6" / 8" / 10"

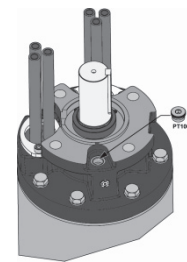

12"

Figure 5-5: Checking the motor fluid

- ⇒ Feed the test pin (1) through the opening in the diaphragm housing (3) (8"/10" de-central cover opening) until resistance is felt.
- ⇒ Measure the actual diaphragm distance to the side of the opening in the diaphragm cover.
If the measured result is not identical to the target value:
44 mm ±2 mm (6"/8" motor)
64 mm ±2 mm (10" motor) or
- ⇒ Top up or drain motor fluid.
- ⇒ 12" – Place the motor vertically and remove the PT100 plug, the fluid level must be on the threaded hole end.

Topping up the motor 6-12"

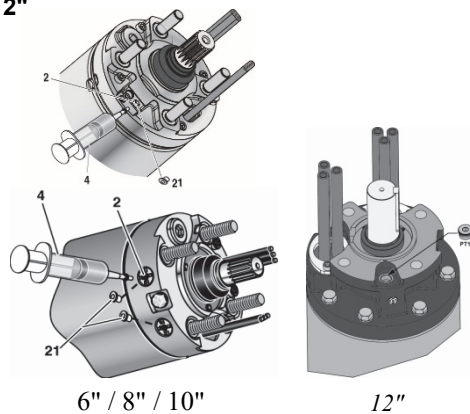

6" / 8" / 10"

12"

Figure 5-6: Topping up the motor fluid

- ⇒ Apply the filling syringe (4) to the filling valve (2).
- ⇒ Top up the motor filling fluid until the value of the diaphragm position is lower than the target value.
- ⇒ 12", remove the PT100 plug screw, overfill the motor with fluid, fit the PT100 plug screw. Start the engine for a short time (no-load), check the fill level again.

Adjusting the motor

- ⇒ Adjust the diaphragm position by draining (see Venting) or topping up motor fluid until the target value is reached. (6" / 8" / 10")
- ⇒ Fit the valve plug (21) again.



Risk of injury from pre-tensioned 8"/10" diaphragm cover during disassembly!

- ⇒ Secure the diaphragm cover: screw the M8 threaded rod through the central cover opening in the diaphragm insert cover.
- ⇒ Lock it from the outside using an M8 locknut.

5.2 Assembling the motor and pump



Note

These assembly and operating instructions only describe action steps related to the motor. You should also observe the pump unit manufacturer's instructions in all events.

Preparation

- Shaft protector removed
- Motor shaft rotated manually before assembly – runs freely after overcoming static friction
- Surfaces of parts to be connected are free from dust and dirt
- Coupling attached to the pump shaft, slides on the motor shaft

Assembly

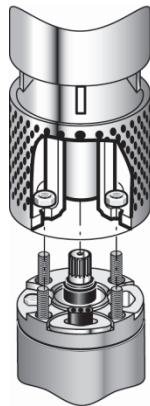

Figure 5-7: 6"

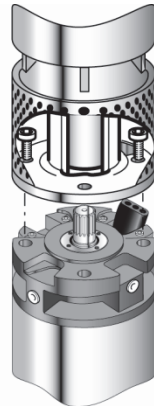

Figure 5-8: 8", 10", 12"

- ⇒ Apply water-resistant, acid-free grease (e.g. Mobil FM 102, Texaco, Cygnus 2661, Gleitmo 746) to the inner part of the coupling to the pump unit.
- ⇒ Make sure that the splined section (with 6" or 8" motors) is encased by an O-ring when the motor and the pump unit are assembled together.
- ⇒ Align the pump unit and motor shaft to each other and connect the pump unit and the motor.



Note

Only use fixing screws of the relevant grade and dimensions approved by the pump unit manufacturer. Observe the indicated torques.

- ⇒ Screw the motor to the pump unit, tighten the fixing screws crosswise as instructed.
6": M12 8": Bore Ø 17.5 mm 10" / 12": Bore Ø 22.0 mm
- ⇒ Protect the coupling location against contact.

5.3 Connecting the drop cable



Motor damage due to damaged motor cable!

- ⇒ Make sure that the motor cable is not in contact with any sharp edges.
- ⇒ Protect the cable against damage using the cable guard.

- ☑ The unit manufacturer's instructions regarding the cable connection have been observed
- ☑ Only extension cable and insulating material used which are suitable for the specific use (specifically drinking water) and which are approved for the temperatures occurring in the relevant medium
- ☑ Cable cross-sections: The tables in the appendix only serve as recommended suggestions. The fitter is responsible for the correct selection and dimensioning of the cable
- ⇒ Lay the cable along the pump.
- ⇒ Connect the ground conductor correctly (motors or integrated ground conductors are prepared for external grounding).
- ⇒ Protect the cable connection location against water penetration (shrink hoses, compounds or ready cable sets).
- ⇒ Make sure that the short motor cable is always fully surrounded by transport medium for proper cooling during operation.

5.4 Measuring the insulation resistance

This measurement is to be carried out using an insulation measuring unit (500 VDC, 1 min) before and while submersing the fully assembled unit at the place of use.

- ⇒ Before submersing the unit, connect a measuring cable to the ground conductor.
- ⇒ Make sure that the contact points are clean.
- ⇒ Connect the other measuring cable to every core of the connected motor cable in succession.

The insulation resistance is shown on the insulation measuring unit.

For your information

Minimum insulation resistance (ambient temperature 20°C) with extension cable:

- for a new motor > 4 MΩ
- for a used motor > 1 MΩ

Minimum insulation resistance (ambient temperature 20°C) without extension cable:

- for a new motor > 400 MΩ
- for a used motor > 20 MΩ

5.5 Powering the motor

Following a new installation or maintenance works of the motor-driven pump system, it is required to carry out a resistant measurement on the earth wire.

This measurement is to be done in compliance with the applicable regulations and with the appropriate measuring devices.



Danger to life due to electrocution!

- ⇒ *Prior to making the electrical motor connection make sure that there is no more voltage on the entire plant and that nobody can accidentally switch on the voltage again while the work is being carried out.*

Energy supply by generator



Note

We urgently recommend that you discuss the plant dimensions with the generator manufacturer.

The voltage tolerance, 50Hz: -10 % to +6 %; 60/100/120Hz: ± 10%,(on the motor terminals) and the deviation of a motor current from the mean value of all three currents must not be more than 5 %.

- ☑ Generator selected based on the motor start behaviour, i.e. starting current with a mean $\cos \varphi$ of 0.5
- ☑ Sufficient continuous generator power available
- ☑ Starting voltage at least 55 % of the nominal voltage

- ⇒ You must follow the following switch-on sequences unconditionally:
first switch on the generator and then the motor.
first switch off the motor and then the generator.

Fusing and motor protection

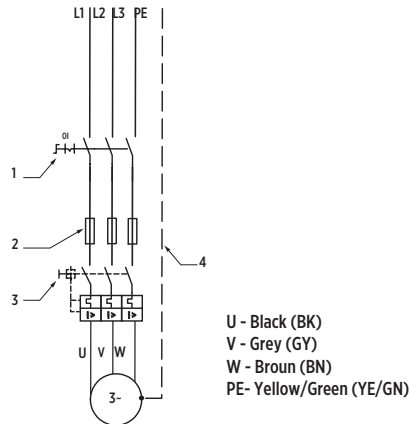

- ⇒ Provide an external mains switch (1) enabling the voltage to be removed from the system.
- ⇒ Provide fuses (2) for every single phase on site.
- ⇒ Provide a motor starting and protection switch (3)(see connection alternatives)
- ⇒ Provide an emergency stop system, if required for your specific application.
- ⇒ Ground the motor (4) (exterior grounding possible with all motors)

Figure 5-10: Fusing and motor protection

Surge voltage protection

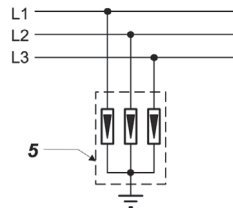

- ⇒ Integrate an overload protector in accordance with IEC 60099 in the power supply (lightning safety (5)).

Figure 5-12: Surge voltage protection

Connection alternatives

The connection example shows the usual circuit with a right-hand field and an anti-clockwise direction of rotation:

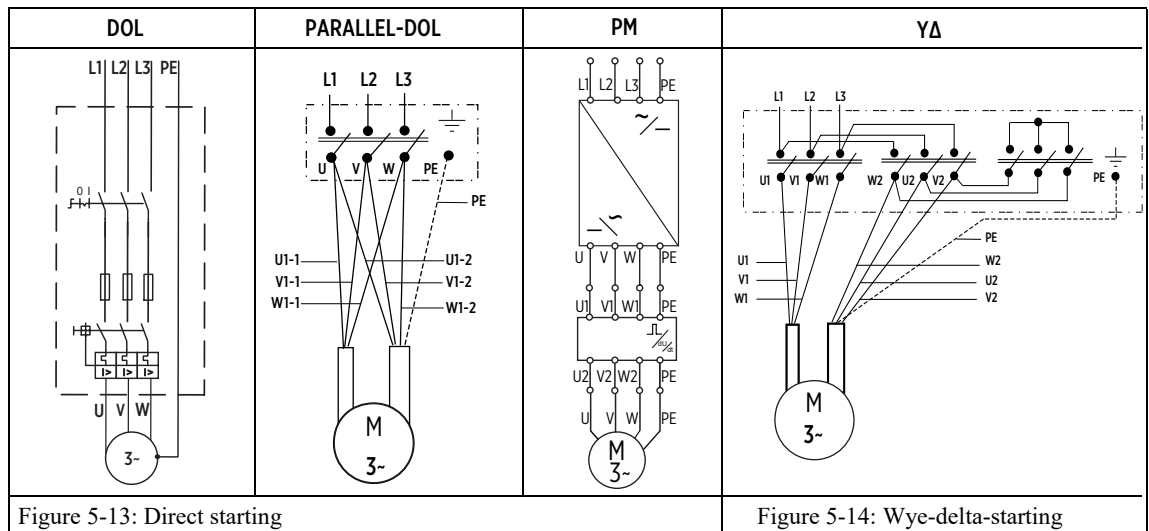

Motor safety switch

A motor safety switch (overload relay) is absolutely necessary!

Only use thermal trips of tripping categories 10A or 10, with

- ⇒ tripping time < 10 s at 500 % I_N (nominal current),
- ⇒ phase sensitivity,
- ⇒ Temperature compensation.
- ⇒ Set the motor protection unit to the value of the operating current measured without exceeding the rated motor current I_N (as indicated on the type plate); recommendation: 90 % of the nominal motor current.

6 Motor Operation

6.1 Proper motor cooling



Caution

Damage to the motor and the motor cable due to overheating

- ⇒ Make sure that the coolant flow speed along the motor is sufficient.
 - ⇒ Make sure that the short motor cable is always fully surrounded by transport medium for proper cooling.
-

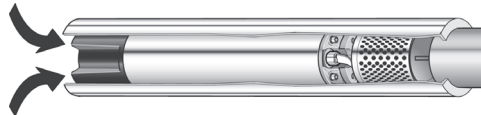

Figure 6-1: Cooling tube

If the required minimum coolant flow speed cannot be reached (e.g. if the inlet opening of the well is located above the motor or if using large-diameter wells):

- ⇒ Fit a cooling tube (see figure 6-1).
- ⇒ Make sure that the cooling tube encases the entire motor and the pump water inlet opening.
The motor is force-cooled.

6.2 Providing a check valve and level sensor

- ⇒ Provide one spring-loaded check valve in the production tube in case no such check valve has been fitted in the pump.
- ⇒ Ensure that the check valve is no further than 7 meters away from the pump.
- ⇒ Install a level sensor for wells with a highly varying water inflow.

6.3 Switching on the motor

- ☑ All action steps of the previous chapter have been carried out properly
- ⇒ Switch on the motor using the mains switch in the control cabinet.
- ⇒ Measure the following values after switching on:
 - Motor operating current in every phase
 - Mains voltage when motor is running
 - Level of the medium to be transported
- ⇒ **Immediately switch off the motor if:**
 - the nominal current as specified on the type plate is exceeded,
 - voltage tolerances of more than, 50Hz: -10 % to +6 %; 60/100/120Hz: ± 10%, relative to the nominal voltage are measured on the motor,
 - there is a risk of the motor running dry,
 - motor current deviates from the mean value of all three currents by more than 5 %.

6.4 Motor operation with frequency converter



Note

When operating a motor with a frequency converter, the relevant operating manual must be observed!

- ⇒ Permanent magnet motors are to be operated by Variable frequency drive (VFD)
- ⇒ VFD operation is only allowable up to a supply voltage of 460 V. For higher voltages, please contact Franklin Electric Europa GmbH
- ⇒ Make sure that the motor current in all operating levels of the regulating range does not exceed the nominal motor current indicated on the type plate.

- ⇒ Adjust the frequency converter so that the limit values for the nominal motor frequency of min. 30 Hz and max. the value of the nominal motor frequency (50 or 60 Hz) are observed.
- ⇒ Limit any voltage peaks on the motor when using a frequency converter to the following values: max. voltage rise 500 V/μs, max. voltage peak 1000 V.
- ⇒ Make sure that the running up time from 0 to 30 Hz and the deceleration time from 30 to 0 Hz is maximum one second.
- ⇒ Dimension the cable such that power loss due to additional filters is taken into consideration.
- ⇒ Make sure that the required coolant flow speed along the motor is also observed with frequency converter operation.

6.5 Motor operation with soft starter



Note

When operating a motor with a soft starter, the relevant operating manual must be observed!

- ⇒ Set the starting voltage of the soft starter to 55 % of the nominal voltage and set the running up and delay times to max. three seconds.
- ⇒ Bridge the soft starter after running up, using a contactor.

6.6 PT100 Trip points

PPC	Winding insulation	75°C
PE2/PA	Winding insulation	75°C
8" PM PE2/PA	Winding insulation	55°C
10" PM PE/2PA	Winding insulation	65°C

7 Maintenance and service

The motor is maintenance-free, no maintenance or service activities are necessary.

8 Troubleshooting

Fault	Remedy
Unusual noises, problems with the proper running of the pump or the pump switching on and off too frequently.	⇒ Try to find the cause of the fault on the pump unit.
The pump repeatedly switches off	⇒ Have the insulation resistance checked by a professional (see chapter 5.4). ⇒ If no cause can be found in the motor or the motor cable: Have the electrical system checked.

9 Service

Repairs must only be carried out by authorised professional workshops (only use original Franklin Electric spare parts).

If you have any questions or problems, please contact your dealer or contact Franklin Electric via Internet (www.franklinwater.eu) or via mail to: field-service@franklin-electric.de.

10 Appendix

Page	Explanation
Page A	Outline drawing 6" and 8"
Page B	Outline drawing 10" and 12"
Page C	Assembly instructions PT100
Page D	Cable cross-sections DOL and YD
Page E - F	Derating Curves



Appendix

A - F

6" Rewindable

304SS / 316SS / 904L

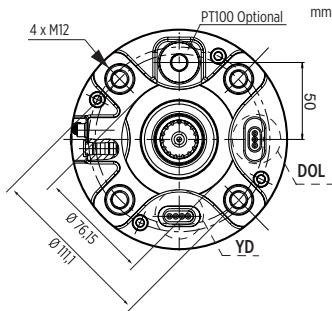
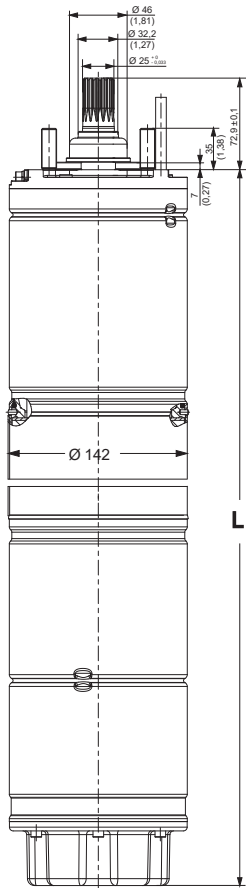

8" Rewindable

304SS / 316SS / 904L

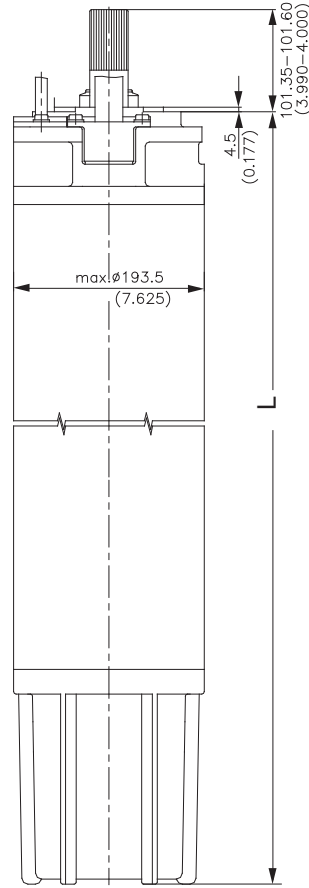

Standard

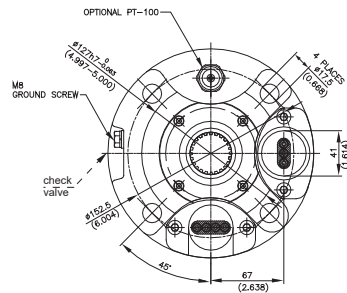

PM

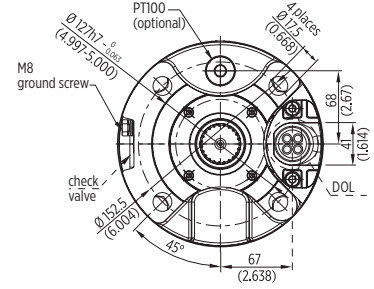

6" Rewindable Motors

P _N [kW]	Standard	Shipping Weight [kg]
	L [mm]	304SS
4	679	48
5,5	679	48
7,5	699	50
9,3	729	54
11	759	58
13	809	62
15	854	66
18,5	899	71
22	989	82
26	1094	93
30	1194	103
37	1274	110

8" Rewindable Motors Standard

P _N [kW]	L [mm]	Shipping Weight [kg]
30	1140	140
37	1140	140
45	1230	156
52	1340	179
55	1340	179
60	1470	198
67	1470	198
75	1560	215
83	1560	247
93	1740	247

8" Rewindable Motors PM

P _N [kW]	L [mm]	Motor Weight [kg]
75	1205	150
100	1316	169
130	1482	204



10" Rewindable
304SS / 316SS / 904L

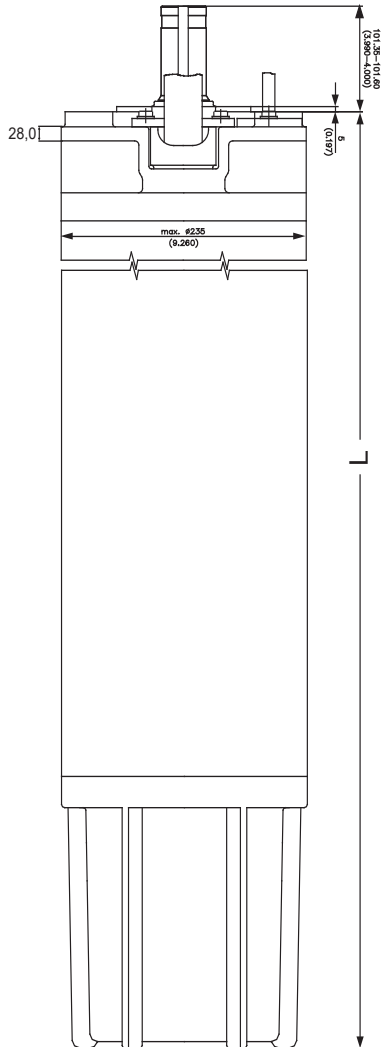

12" Rewindable
304SS / 316SS

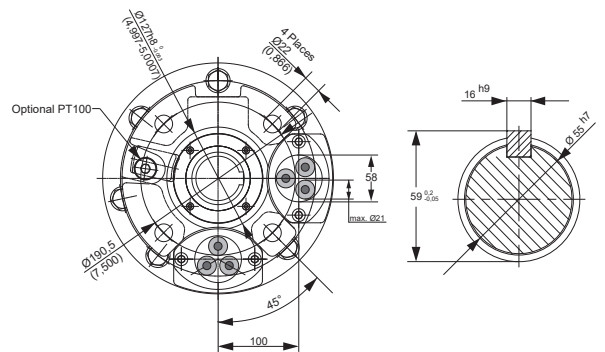
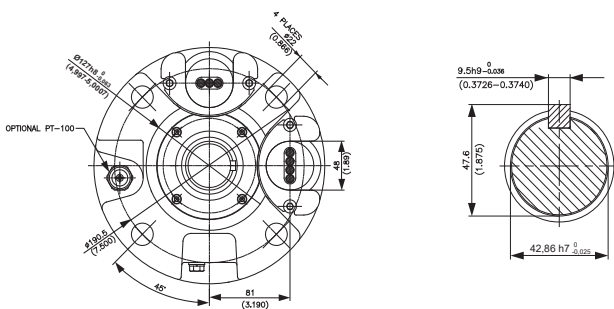
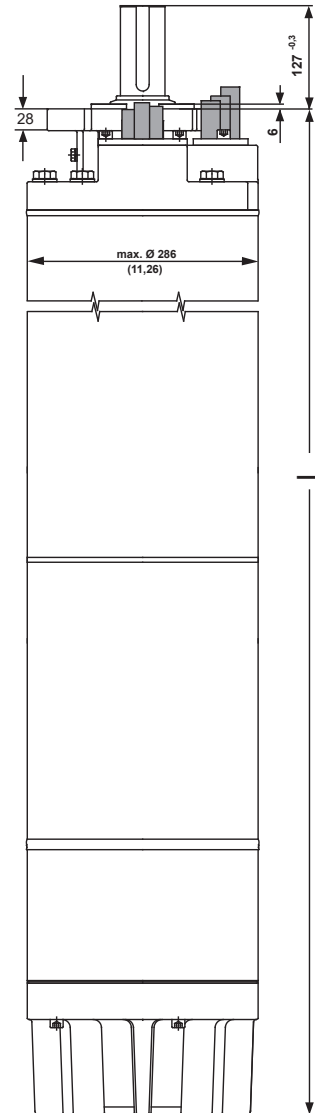

10" Rewindable Motors Standard			10" Rewindable Motors PM		
P_N [kW]	L [mm]	Motor Weight [kg]	P_N [kW]	L [mm]	Motor Weight [kg]
85	1419	280	150	1549	311
110	1529	315	200	1659	331
130	1659	362	250	1769	350
150	1769	413			
185	1919	449			

12" Rewindable Motors Standard		
P_N [kW]	L [mm]	Motor Weight [kg]
185	1703	595
220	1893	663
250	1893	663
300	2043	726
350	2143	769
400	2193	794

Installation manual PT100
Rewindable Motors 6" / 8" / 10" / 12"

Required parts and tools

- PT 100 Kit 304/316: (308 016 66.)
 904L: (308 016 67.)
- Filling – Kit: (308 726 103)



- Wear safety goggles and protective gloves when emptying and filling the motor.
- Do not exert any strain force on the PT100.

Pressure compensation (Fig. 2)

Stand the motor vertically and remove the plug (21) from the filling valve. Remove the plunger from the syringe (4) and carefully insert it into the valve. Collect the escaping liquid in a clean container. When no more liquid remains, there is no longer any pressure in the motor. You can now remove the syringe.

PT100 assembly 304SS/316SS Motors 6" - 10"

Remove the screw plug (21) in the end bell. Prepare the PT100 according to the motor version (Fig. 1). Now insert the PT100 until it stops. Tighten the union nut to the stop. **CAUTION: For 6" motors, ensure that the union nut does not extend out over the pump seat (Fig. 5).**

PT100 assembly WW/304SS/316SS Motors 12"

Remove the screw plug (21). Fill the motor with filling liquid or clear drinking water up to the lower end of the PT100 hole. Insert the PT100 to the stop and tighten the union nut. The 12" motor is now ready for operation.

PT100 assembly 904L Motors 6" - 12"

Remove the screw plug (21) in the end bell. Prepare the PT100 according to the motor version (Fig. 1). Mark the PT100 cable at 80mm from the end of the PT100 sensor (Fig. 4). Now insert the PT100 up to the marking and tighten the union nut.

Preparing for operation and checking 6" - 10" Motors

Remove the screw plug (21) in the end bell. Verwenden Sie die Spritze (3) um den Motor mit Füllflüssigkeit oder klarem Leitungswasser aufzufüllen. Die Membranposition sollte nach dem Auffüllen kleiner sein als:

Diaphragm position	6"/8"	44 mm ±2
	10"	64 mm ±2

Checking 6" - 10" Motors (Fig. 6):

Position the motor so that the filling valve is in the highest position. Carefully insert the test pin (1) into the filling valve to allow the air to release. If filling fluid is released without bubbles, the motor is air-free.

6" Motors: Insert the test pin (1) into the central port of the diaphragm housing (Fig 6).

8 - 10" Motors: Insert the test pin (1) into the off-center port of the diaphragm housing (Fig 6).

Check the distance between the diaphragm and the outer end of the hole. You can adjust the membrane distance to the specified values by filling or draining the filling liquid. Reinsert the filter plug (21) into the filling valve screw.

Electric installation:

Adjusting switching equipment- Trip points
 see operating instructions of the motor

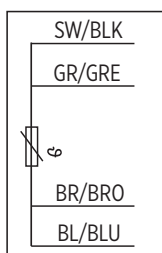

(Fig.3) PT100 Preparation for mounting in REW motors

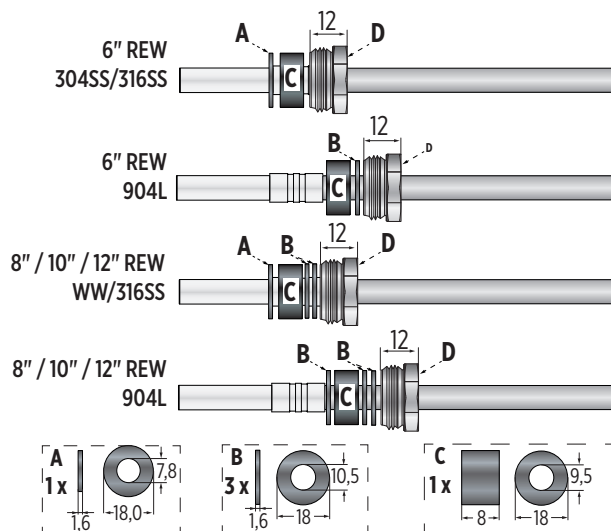

(Fig.2) Pressure relief

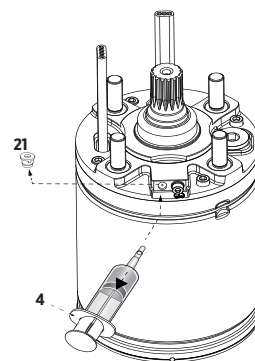

(Fig.4)

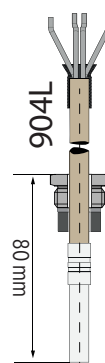

(Fig.6) Diaphragm fill level check

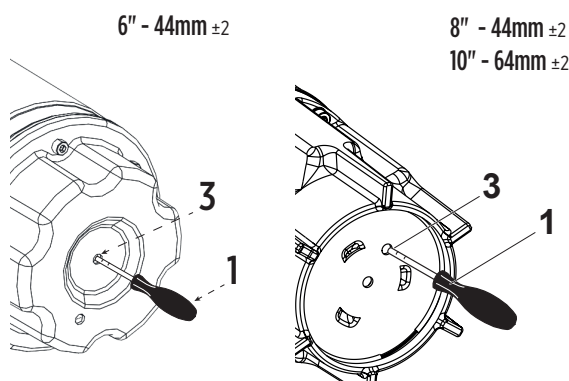

(Fig.3) Filling & bleeding

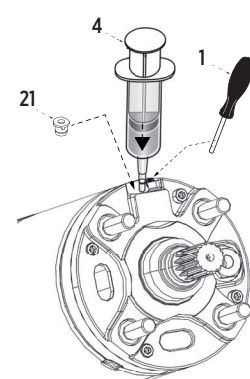

(Fig.5)

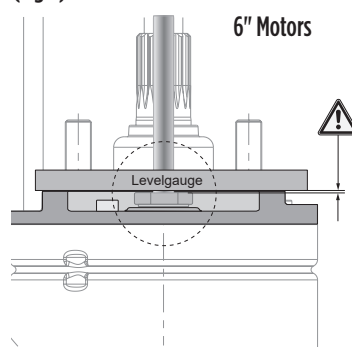



maximum lengths in meters for 400V / 50Hz and 3% voltage drop at 50°C ambient temperature and 90°C at copper wire
Jacketed Drop Cable Length

rating		DOL - Delta start																	
		cable size mm ² , copper wire - 90°C rated insulation																	
KW	HP	2,5	4	6	10	16	25	35	50	70	95	120	150	185	240	300	400	500	
4	5,5	95	155	230	385	605	915												
5,5	7,5	70	110	170	280	440	670	915											
7,5	10	50	80	126	205	325	500	685	935										
9,3	12,5	40	65	100	170	270	410	565	770	1030									
11	15		55	85	140	225	345	470	645	865	1110								
13	17,5		50	75	125	195	300	410	560	750	965								
15	20		40	65	105	170	265	360	495	665	855	1030							
18,5	25			50	85	140	210	290	400	530	680	810	950						
22	30				75	120	180	250	340	455	585	700	815	945					
26	35				60	100	150	210	290	385	500	600	705	815	970				
30	40					85	135	185	250	335	430	515	600	695	820	935			
37	50						105	150	205	270	350	420	485	565	665	760	875	980	
45	60						90	125	175	235	310	375	445	520	630	730	860	980	
52	70						80	110	155	210	270	325	385	450	540	625	735	840	
55	75							105	145	195	255	305	360	420	505	580	685	770	
60	80							95	135	185	240	290	345	400	485	560	660	750	
67	90								120	160	210	255	300	350	415	480	565	640	
75	100								105	145	185	225	270	315	375	435	510	580	
83	111								95	130	170	210	250	290	350	405	480	540	
85	114									125	160	195	230	265	315	365	425	480	
93	125									115	150	185	215	255	300	350	410	460	
110	150										120	145	170	200	235	270	310	350	
130	175											130	155	180	215	250	290	330	
150	200												145	170	205	235	275	280	
185	250														140	160	185	210	
220	300														130	150	175	200	
250	335															125	145	160	
300	400																	150	
350	470																		120
400	540																		

rating		Wye - Delta start																	
		cable size mm ² , copper wire - 90°C rated insulation																	
KW	HP	2,5	4	6	8,4	10	16	25	35	50	70	95	120	150	185	240	300	400	500
4	5,5	145	230	350	485	575	900												
5,5	7,5	106	170	250	350	420	660	1010											
7,5	10	75	125	185	260	310	490	750	1025										
9,3	12,5	60	100	155	215	255	405	620	845	1160									
11	15	50	85	130	180	210	340	520	715	980									
13	17,5	45	75	110	155	185	295	450	615	845	1125								
15	20	40	65	95	135	160	260	395	540	740	995								
18,5	25	30	50	80	110	130	210	320	435	600	800	1025							
22	30		45	65	95	110	180	275	375	510	685	875	1050						
26	35		35	55	80	95	150	230	315	435	580	750	900	1055					
30	40			50	70	80	130	200	275	375	500	645	775	905	1045				
37	50				55	65	105	160	220	305	410	525	625	730	845	1000			
45	60					55	90	135	190	260	355	460	560	665	780	945	1095		
52	70					50	80	120	165	230	310	405	490	580	680	815	940		
55	75						75	115	155	220	295	380	460	545	635	760	875	1025	
60	80						70	105	145	205	275	360	435	510	605	725	840	990	1130
67	90						60	95	130	180	240	315	380	450	525	625	720	845	960
75	100							85	115	160	215	280	340	405	470	565	655	765	875
83	111							75	105	145	200	260	315	375	435	525	610	715	820
85	114							70	100	135	185	240	290	345	400	475	550	640	725
93	125							65	95	130	175	230	275	325	380	455	525	615	695
110	150									105	140	180	220	255	300	355	405	465	525
130	175									95	125	160	195	230	270	325	375	435	495
150	200										105	140	170	200	230	275	320	400	420
185	250											110	130	155	180	210	240	280	315
220	300												115	140	160	195	225	260	300
250	335													105	125	140	170	190	220
300	400														110	125	150	175	205
350	470																125	145	170
400	540																	110	130

* only for individual conductor cable

6" Rewindable De-Rating Curves

De-Rating of 6" Rewindable Motors 4 - 15 kW

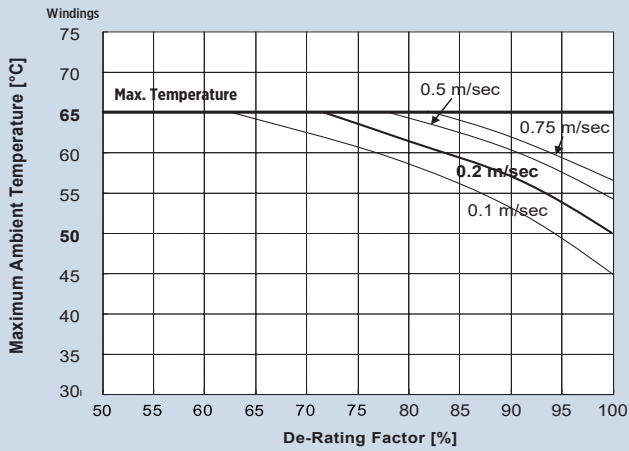

valid from: 05.2025

De-Rating of 6" Rewindable Motors 18,5 - 30 kW

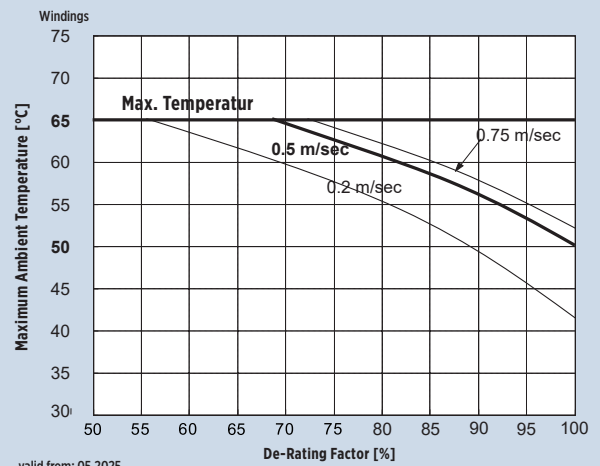

valid from: 05.2025

De-Rating of 6" Rewindable Motors 37 kW

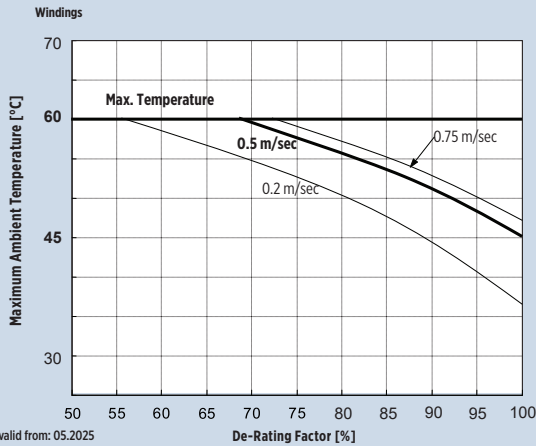

valid from: 05.2025

8" Rewindable De-Rating Curves

De-Rating of 8" Rewindable Motors 30 - 52 kW

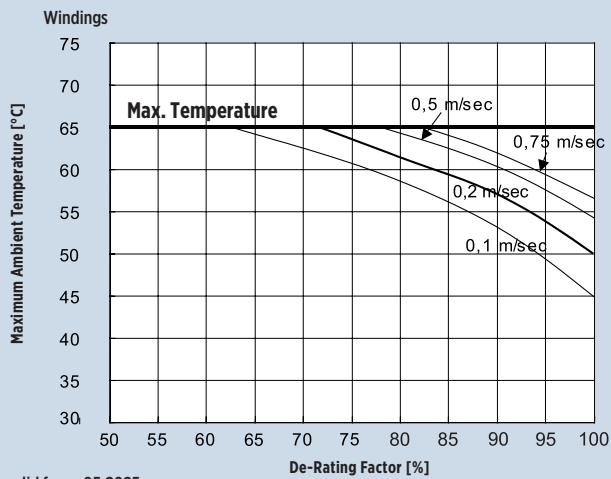

valid from: 05.2025

De-Rating of 8" Rewindable Motors 55 - 93 kW

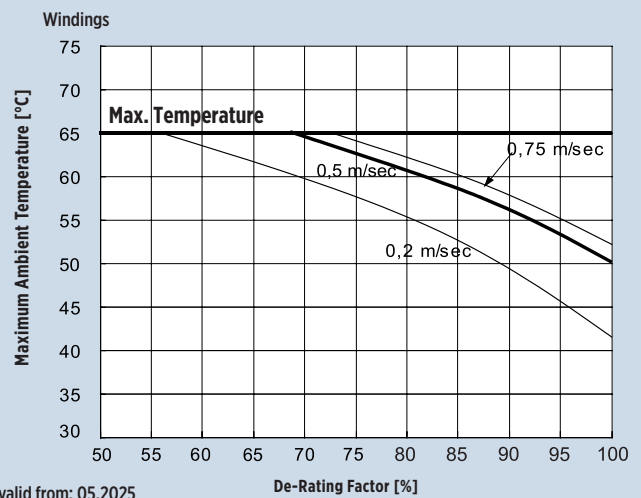

valid from: 05.2025

If these conditions are not met please contact Franklin Electric !



Franklin Electric

Franklin Electric Europa GmbH
Rudolf Diesel Strasse 20
54516 Wittlich / Germany
E-Mail: field-service@franklin-electric.de

Single member - Company subject to the control
and coordination of Franklin Electric Co., Inc.

NOTE: Franklin Electric Europa GmbH reserves the right to amend specification without prior notice.