



**Franklin Electric**

# VARIABLE FREQUENCY DRIVES

DRIVES FOR THE USE WITH FRANKLIN ELECTRIC PUMPING SYSTEMS





# INDEX

Variable Frequency Drives .....	4
Cerus® X-Drive .....	6
DrivE-Tech MINI .....	11
DrivE-Tech COMPACT .....	13
DrivE-Tech.....	16
Variable Frequency Solar Drives .....	20
Variable Frequency Drive Selection Guide .....	24
Input Filter .....	25
Output Filter .....	26
Output Filter Accessories .....	31
Variable Frequency Drive Accessories .....	32

Franklin Electric reserves the right to amend specification without prior notice. For the most up-to-date product information, visit [franklinwater.eu](http://franklinwater.eu).

## VARIABLE FREQUENCY DRIVES

Franklin Electric Variable Frequency Drives are designed to work in a wide range of submersible and surface pumping applications. They are offering great flexibility, state of the art motor protection, energy savings and enhanced pump speed control while remaining easy to use.

The innovative and reliable design allows multi-purpose use across many industries and key applications such as residential constant water pressure, municipal water supply, agriculture and irrigation, dewatering and mining.



**DrivE-Tech MINI**

IP66 wall mounted /  
Pump mounted drive



**DrivE-Tech COMPACT**

IP66 wall mounted/  
Pump mounted drive



**DrivE-Tech**

IP65/54 wall mounted/  
Pump mounted drive



**Cerus X-Drive**

IP20/00 /  
Panel mounted drive

DrivE-Tech Series  
0.55 - 130 kW

CERUS X-Drive  
4.0 - 250 kW

## APPLICATIONS



# VARIABLE FREQUENCY DRIVES

## FEATURES & BENEFITS

The DrivE-Tech and Cerus X-Drive are variable frequency drives designed to control and protect three phase asynchronous and permanent magnet synchronous motors in residential, industrial, municipal, and agricultural applications. They are easy to integrate into existing infrastructure or to be used as stand-alone drive modules for individual pumping applications.

- ✓ Enhanced pump speed control
- ✓ State of the art motor and pump protection features
- ✓ Operation of induction type asynchronous motors and permanent magnet synchronous motors
- ✓ Wide performance range up to 250 kW
- ✓ Compact, innovative and reliable design
- ✓ Bluetooth connectivity and Mobile App control
- ✓ Remote Support, commissioning, and support
- ✓ CE approved

## EASY INSTALLATION & SUPPORT

- ✓ Intuitive start-up experience with application-specific parameter pre-sets
- ✓ Setup/commissioning through user-friendly Mobile App or keypad
- ✓ Copy-paste parameter setup between multiple drives through keypad data storage or Mobile App

Unyconnect App for DrivE-Tech Series:

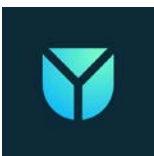

Google Playstore



Apple App Store

FE CONNECT App for X-Drive Series:



Google Playstore



Apple App Store

# CERUS® X-DRIVE

The Cerus X-Drive is a variable frequency drive that offers an extensive range of amperage and configuration options, making it versatile enough for nearly any constant or variable torque application. Industry standard application settings are pre-configured for submersible or centrifugal pumps, supply or exhaust fans, cooling towers, vacuum pumps, and constant torque and permanent magnet motors. In addition, many input/output and control options are available for application specific features, such as PID speed control, pressure control, temperature or level controls.

## FEATURES & BENEFITS

### CONFIGURATION

- Compatible with three-phase induction or permanent magnet motors
- Extensive selection of models available
- Easy setup with built-in application defaults
- Many programmable Input/Output terminal options
- Available in IP20 / 00 enclosure offerings

### APPLICATION-SPECIFIC FEATURES

- Many pump specific features such as constant pressure, flow, level control
- Pump screen clean
- Broken pipe detection
- Dual demand controls
- Automated scheduling
- Multi-drive booster control

### OPERATION

- Integrated HAND-OFF-AUTO switch functionality
- Integrated display with keypad control of all functions
- Real-time fault logging with date and time stamps

### PROTECTION

- PT100 motor temperature protection, Protection against short circuit, incorrect wiring, surges, underload, overload, drive overheat, undervoltage, overvoltage, phase loss, phase imbalance, output open phase, overpressure, sensor fault, etc.
- Pump dry run
- Locked rotor or pump
- The X-Drive allows your motor to gradually ramp up and down, saving equipment from sudden, harsh rushes of current that can shorten its lifespan.

### COMMUNICATION

- RS-485 communication (Modbus, BACnet) for remote control or monitoring
- Bluetooth connectivity with Cerus X-Drive Mobile App
- Communications for multi-drive operations up to 8 VFDs
- One-to-One™ Remote control feature



One-to-One™  
Remote control feature



permanent magnet technology

# CERUS X-DRIVE

## MODEL NO. CODES

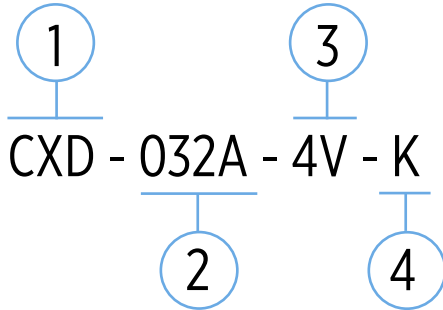

1. **Product family:**  
Cerus X-Drive Series
2. **Output Amperage ratings:**  
5 - 930 A
3. **Input voltage:\***  
2 V = 200/230 V  
4 V = 460 V → 380-500 V  
6 V = 575 V
4. K = drive incl. Bluetooth plug-in-card

\*2 and 6 V models on request



# CERUS X-DRIVE

## MODEL NUMBER CERUS X-DRIVE

drive model no.	drive type	IP	V <sub>in</sub> [V]	I <sub>out</sub> [A]	dimensions				weight [kg]	Frame size
					a	b	c	d		
CXD-013A-4V-K	X-Drive 13A	IP	3x380-500	13	130	250		170	3	A
CXD-018A-4V-K	X-Drive 18A	20	3x380-500	18	130	250		170	3	A
CXD-024A-4V-K	X-Drive 24A	20	3x380-500	24	190	320		190	5.5	B
CXD-032A-4V-K	X-Drive 32A	20	3x380-500	32	190	320		190	5.5	B
CXD-038A-4V-K	X-Drive 38A	20	3x380-500	38	190	320		190	5.5	B
CXD-045A-4V-K	X-Drive 45A	20	3x380-500	45	250	400		210	10	C
CXD-060A-4V-K	X-Drive 60A	20	3x380-500	60	250	400		210	10	C
CXD-073A-4V-K	X-Drive 73A	20	3x380-500	73	250	400		210	10	C
CXD-091A-4V-K	X-Drive 91A	20	3x380-500	91	280	500	614	255	27	DO
CXD-110A-4V-K	X-Drive 110A	20	3x380-500	110	280	500	614	255	27	DO
CXD-150A-4V-K	X-Drive 150A	20	3x380-500	150	330	550	688	275	40	D
CXD-180A-4V-K	X-Drive 180A	20	3x380-500	180	330	550	688	275	40	D
CXD-220A-4V-K	X-Drive 220A	20	3x380-500	220	370	589	716	300	65	E
CXD-260A-4V-K	X-Drive 260A	20	3x380-500	260	370	589	716	300	65	E
CXD-310A-4V-K	X-Drive 310A	20	3x380-500	310	420	800	940	300	87	F
CXD-370A-4V-K	X-Drive 370A	20	3x380-500	370	420	800	940	300	87	F
CXD-460A-4V-K	X-Drive 460A	20	3x380-500	460	500	1000	1240	397	135	G
CXD-530A-4V-K	X-Drive 530A	20	3x380-500	530	500	1000	1240	397	135	G

\* Optional input filter on request (X-Drive 13A - 73A)

## OUTLINE DIMENSIONS

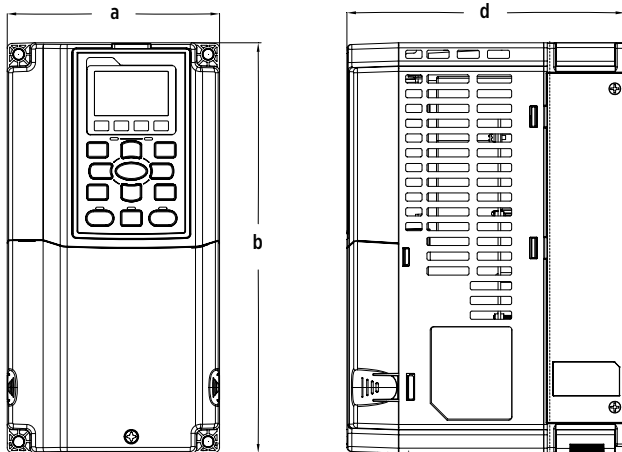

**Cerus X-Drive**  
Frame A, Frame B, Frame C

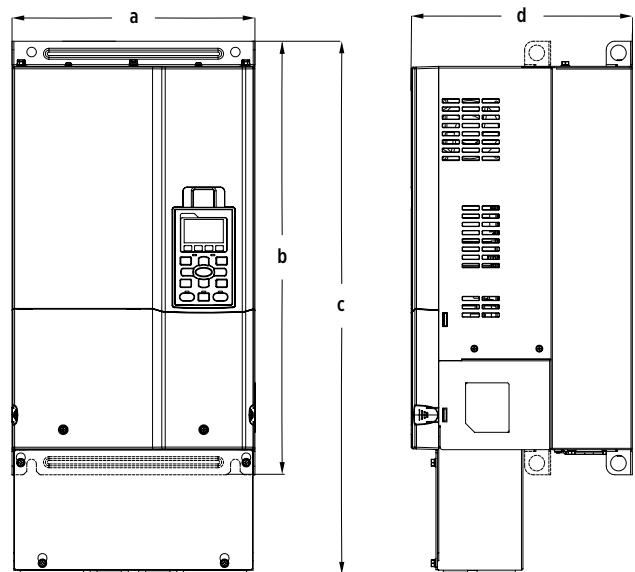

**Cerus X-Drive**  
Frame D, Frame DO, Frame E, Frame F, Frame G

# CERUS® X-DRIVE SPECIFICATION

Mains Connection	Input voltage	3ph 380-460 V	
	Input frequency	50-60 Hz	
	Displacement power factor (cosphi)	> 0.98	
Motor controls	Control methods	V/F and SVC (Sensorless Vector Control)	
	Control type	PWM (Pulse Width Modulation)	
	Frequency Setting Resolution	Digital Reference: 0.01 Hz (Below 100 Hz), 0.1 Hz (Over 100 Hz) Analog Reference: [Max. output frequency] x 0.03 / 60 Hz (±11 bit)	
	Frequency Accuracy	Digital: 0.01 % of Max. Output Frequency, Analog: 0.1 % of Max. Output Frequency	
	V/F Control Curve	12 preset V/F curves and four-point square curve	
	Speed Control Ratio	1:12 (50 Hz - 60 Hz) at 60 Hz maximum frequency	
	Maximum Output Frequency	380- 460VAC models: 599 Hz (90 kW and above: 400 Hz)	
	Overload Capacity	Variable torque: 120% of VFD rated current for 1 minute during every 5 minutes of operation Constant torque: 150% of VFD rated current for 1 minute during every 5 minutes of operation and 160 % for 3 seconds during every 25 seconds of operation	
Operation	Operation Method	Keypad / Terminals / RS-485 BACnet or Modbus Communication / Optional Modbus TCP/IP & Ethernet IP Communication	
	Analog Input	Two analog inputs 0- 10 VDC/ 4- 20 mA and one AI 0-10 VDC. Digital: Keypad or Communication	
	By Digital Inputs	Start Signal	Forward, Reverse and Jog (some features can start and stop VFD based on analog signal).
		Digital Input	8 programmable digital inputs can be set to any selection from long list of functions
		Multi-Step	Up to 17 speeds can be set including Jog by programmable digital inputs.
		Jog	Jog operation with adjustable Jog frequency
		Fault Reset	Resets VFD faults via keypad, digital input or communication. Some critical faults can only be reset by cycling the VFD power.
	Safety Inputs	SCM and STO terminals for safety circuit wiring	
	Outputs	Three Multi-Function Relays	One relay with Form C: 250VAC 3A/30VDC, 3A (resistive) 1.2A (inductive) contact, Two relays with Form A: 250VAC 1.2A/30VDC 3A (resistive) 1.2A (inductive), Each relay can be programmed to any selection from the functions list.
		Two Analog Outputs	Selections: Output Frequency, Output Current, Output Voltage, Output kW, DC Link Voltage, AVI1, ACI, AVI2 AI signal level. Both outputs are 0-10VDC scalable from 10 to 200%.
General Operation Functions	DC Braking, Frequency Limit, Jump Frequencies, 2nd ACC/DEC, Auto Restart, Auto-Tuning, PID w/sleep, Flying Start, Speed Search, DC Braking, Slip Compensation, Motor Pre-heat, Temperature Foldback, Damper Control, Fireman's Override, Shutdown, Power-on Delay, Run Delay, Minimum Run Timer, PM Motor and Auto-Tuning.		
Pump Operation Functions/Protections	Sleep Mode with Pressure Boost, Pipe Fill, PID, Overpressure, ULD (Underload), HLD (High Load), Broken Pipe, Backspin Timer, MMC, Lubrication, Screen Clean, No-Flow Protection, Pump Prime Time		
Protection	VFD Fault Trips	Over Voltage, Low Voltage, Over Current, Overload, Short Circuit, Ground Fault, VFD Overheat, Input Phase Loss, Output Phase Open, CPU Communication Error, Signal Loss, Hardware Fault, etc.	
	Motor temperature	3-wire PT100 motor temperature protection	
	Motor Overload	Adjustable electronic motor overload protection.	
	Overcurrent	380/400/440/460 VAC Variable Torque: At 200% of VFD rated current, 380/400/440/460 VAC Constant Torque: At 240% of VFD rated current, Current clamp: Variable Torque: 130- 135%, Constant Torque 170- 175% 575 VAC models: At 225% VFD rated current; Current clamp: Variable Torque: 128- 141%, Constant Torque: 170- 175%	
	Overvoltage	380-460 VAC models: At 820VDC DC bus voltage	
	VFD Overtemperature	Built-in IGBT and Capacitor Bank temperature sensors	
	VFD Alarm	Stall Prevention at ACC and DEC, Overload, Thermal Sensor Fault, Capacitors High Temperature, Signal Loss, Overpressure, Underload, High Load, etc.	
Keypad Display	Operation Information	Output Frequency, Output Current, Output Voltage, Frequency Reference, Operating Speed, DC Voltage, kWattmeter, Run-time, Last Trip Time, Pressure, etc.	
	Fault history	Provides 6 fault records and logs 30 faults	

## CERUS® X-DRIVE SPECIFICATION

Environment	Operating Temperature	IP21: 14°F - 104°F (-10°C - 40°C), IP00: 14°F - 122°F (-10°C - 50°C)
	Storage temperature	-13°F - 158°F (-25°C - 70°C)
	Ambient Humidity	up to 95 % RH. (non-condensing)
	Altitude	Normal up to 3300 ft (1000 m). At altitude up to 2,000 m, de-rate by 1% of rated current or lower 0.5 °C of temperature for every 10 m above 1000 m. Maximum altitude for corner grounded TN system is 2 000 m. For application over 2 000 m, please contact FELE for more details.
	Vibration and Impact	1 mm peak to peak value from 2 Hz to 13.2 Hz; 0.7G - 1.0G from 13.2 Hz to 55 Hz; 1.0G from 55 Hz to 512 Hz. Comply with IEC 60068-2-6 and IEC/EN60068-2-27.
	Environmental Conditions	Pollution degree 2. No corrosive gas, combustible gas, oil mist or dust, IEC60721-3-3/ IEC60364-1/ IEC60664-1
	Enclosure Ratings	IP20/00
Agency Approvals	UL	UL508C, UL/cUL
	CE Low Voltage	EN6100-5-1
	CE EMC	EN61800-3, EN61000-3-12, IEC61000-4-2, IEC61000-4-3, IEC61000-4-4, IEC61000-4-5, IEC61000-4-6, IEC61000-4-8, IEC61000-6-2, IEC61000-6-4
	Other	C-Tick, ROHS

## DRIVE-TECH MINI

The Drive-Tech MINI is an easy-to-use, versatile and highly featured variable frequency drive. It can be used in a wide range of pumping applications, from the residential household constant pressure control to light commercial multi-pump pressure boosting. Combined with specifically designed features, mobile app with remote control and a robust IP66, outdoor-rated, enclosure the Drive-Tech MINI improves, controls and protects surface or submersible pumping systems.

### FEATURES & BENEFITS

#### CONFIGURATION

- Compatible with three-phase induction or permanent magnet motors
- Available in 1-230V IN / 3-230V OUT or 3-400V IN / 3-400V OUT
- Easy setup with multi level user access and presets
- Programmable Input/Output terminal options
- Outdoor rated IP66 enclosure for use in harsh environments
- Direct wall mount and surface pump mounting
- Low harmonic drive design to meet EN61000-3-12
- Integrated Input filter for use in first environment C1 EN61800-3



#### APPLICATION-SPECIFIC FEATURES

- Pump specific features, including: constant water pressure, flow, level control
- Multi pump operation controlling a second pump at constant speed
- Combo operation connecting up to 8 Drive-Tech MINI units
- Alternating pump mode
- Surface or submersible pump cascading
- Constant speed mode with 2 setpoints

#### OPERATION

- Integrated multi row OLED display showing alarms, pump speed, set point and more
- Fully controllable through Unyconnect mobile app
- Real-time fault logging with date and time stamps
- MPPT control for PV-panel powered solar pumping applications
- Multi power operation allows to use AC and DC supply voltage

#### PROTECTION

- Protection against short circuit, surges, underload, overload, drive overheat, undervoltage, overvoltage, phase loss, phase imbalance, overpressure, sensor fault, etc.
- Pump dry run
- Locked rotor or pump

#### COMMUNICATION

- RS-485 Communications (Modbus) multi pump operation, remote control and monitoring
- Bluetooth connectivity with Unyconnect mobile app
- Bridge mode using 2 smartphones and GSM/Wifi connection for permanent remote control
- Communications for multi-drive operations up to 8 VFDs

# DRIVE-TECH MINI

## MODEL NUMBER DRIVE-TECH MINI

Drive model no.	drive type	IP	V <sub>IN</sub> [V]	I <sub>OUT</sub> [A]	dimensions [mm]	weight [kg]
002149005	DT MINI 2.005 M/T	66	1x220-240	3	150 x 211 x 130	2.5
002149112	DT MINI 2.011 M/T	66	1x220-240	5	150 x 211 x 130	2.5
002149152	DT MINI 2.015 M/T	66	1x220-240	7.5	150 x 211 x 130	2.5
314000170	DT MINI 2.022 M/T	66	1x220-240	8.5	150 x 211 x 130	2.5
314000162	DT MINI 4.011 T/T	66	3x380-460	4	150 x 211 x 130	2.5
314000163	DT MINI 4.022 T/T	66	3x380-460	6	150 x 211 x 130	2.5
314000164	DT MINI 4.040 T/T	66	3x380-460	10.5	150 x 211 x 130	2.5



drive model no.	drive type	IP	V <sub>IN</sub> [V]	VDC <sub>IN</sub> [V]	I <sub>OUT</sub> [A]	dimensions [mm]	weight [kg]
314000165	DT MINI Solar 2.005 M/T	66	1x220-240	400	3	150 x 211 x 130	2.5
314000166	DT MINI Solar 2.011 M/T	66	1x220-240	400	5	150 x 211 x 130	2.5
314000167	DT MINI Solar 2.015 M/T	66	1x220-240	400	7.5	150 x 211 x 130	2.5

## OUTLINE DIMENSIONS

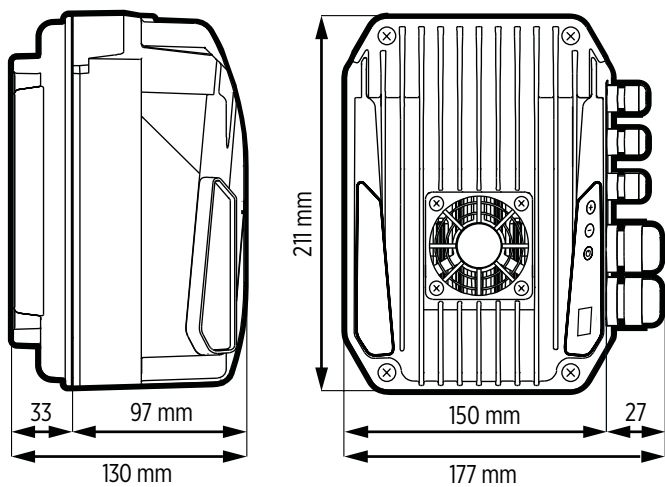

## DRIVE-TECH COMPACT

The Drive-Tech COMPACT is designed and developed to maintain existing features of the Drive-Tech MINI while extending the operation range up to 22 kW. It is dedicated to improving submersible or surface pumping systems in many different applications like municipal water supply, irrigation, commercial pressure boosting, HVAC and many more. The combination of high feature set, an extended operation range and compact while robust enclosure design, makes it ideal for nearly any stand-alone decentralized pumping application.

### FEATURES & BENEFITS

#### CONFIGURATION

- Compatible with three-phase induction or permanent magnet motors
- Available in 1-230V IN / 3-230V OUT or 3-400V IN / 3-400V OUT
- Optional integrated plug-in output filter card
- Low harmonic drive design to meet EN61000-3-12
- Integrated Input filter for use in first environment C1 EN61800-3
- Easy setup with multi level user access and presets
- Programmable Input/Output terminal options
- Outdoor rated IP66 enclosure for use in harsh environments
- Direct wall mount and surface pump mounting

#### APPLICATION-SPECIFIC FEATURES

- Pump specific features, including: constant water pressure, flow, level control
- Multi pump operation controlling a second pump at constant speed
- Alternating pump mode
- Surface or submersible pump cascading
- Constant speed mode with 2 setpoints

#### OPERATION

- Integrated multi row OLED display showing alarms, pump speed, set point and more
- Fully controllable through Unyconnect mobile app
- Real-time fault logging with date and time stamps
- MPPT control for PV-panel powered solar pumping applications
- Multi power operation allows to use AC and DC supply voltage

#### PROTECTION

- Protection against short circuit, surges, underload, overload, drive overheat, undervoltage, overvoltage, phase loss, phase imbalance, overpressure, sensor fault, etc.
- Pump dry run
- Locked rotor or pump
- PT100 motor temperature protection on request (running change available end of Q4/2023)

#### COMMUNICATION

- RS-485 Communications (Modbus) multi pump operation, remote control and monitoring
- Bluetooth connectivity with Unyconnect mobile app
- Bridge mode using 2 smartphones and GSM/Wifi connection for permanent remote control
- Communications for multi-drive operations up to 8 VFDs



# DRIVE-TECH COMPACT

## MODEL NUMBER DRIVE-TECH COMPACT

drive model no.	drive type	IP	V <sub>IN</sub> [V]	I <sub>OUT</sub> [A]	dimensions [mm]	weight [kg]
002152090	DT COMPACT 2.022 M/T	66	1x220-240	9.5	248 x 337 x 190	10
002152120	DT COMPACT 2.030 M/T	66	1x220-240	12.5	248 x 337 x 190	10
002152180	DT COMPACT 2.040 M/T	66	1x220-240	18.5	248 x 337 x 190	10
002150140	DT COMPACT 4.055 T/T	66	3x380-460	14	248 x 337 x 190	10
002150180	DT COMPACT 4.075 T/T	66	3x380-460	18	248 x 337 x 190	10
002150250	DT COMPACT 4.110 T/T	66	3x380-460	25	248 x 337 x 190	10
002150300	DT COMPACT 4.150 T/T	66	3x380-460	30	248 x 337 x 190	10
002150380	DT COMPACT 4.185 T/T	66	3x380-460	38	248 x 337 x 190	10
002150440	DT COMPACT 4.220 T/T	66	3x380-460	44	248 x 337 x 190	10



drive model no.	drive type	IP	V <sub>IN</sub> [V]	I <sub>OUT</sub> [A]	dimensions [mm]	weight [kg]
002150141	DT COMPACT Solar 4.055 T/T	66	3x380-460	14	248 x 337 x 190	10
002150181	DT COMPACT Solar 4.075 T/T	66	3x380-460	18	248 x 337 x 190	10
002150251	DT COMPACT Solar 4.110 T/T	66	3x380-460	25	248 x 337 x 190	10
002150301	DT COMPACT Solar 4.150 T/T	66	3x380-460	30	248 x 337 x 190	10
002150381	DT COMPACT Solar 4.185 T/T	66	3x380-460	38	248 x 337 x 190	10
002150441	DT COMPACT Solar 4.220 T/T	66	3x380-460	44	248 x 337 x 190	10

drive model no.	drive type	IP	V <sub>IN</sub> [V]	I <sub>OUT</sub> [A]	dimensions [mm]	weight [kg]
002150142	DT COMPACT 4.055 T/T PT100	66	3x380-460	14	248 x 337 x 190	10
002150182	DT COMPACT 4.075 T/T PT100	66	3x380-460	18	248 x 337 x 190	10
002150252	DT COMPACT 4.110 T/T PT100	66	3x380-460	25	248 x 337 x 190	10
002150302	DT COMPACT 4.150 T/T PT100	66	3x380-460	30	248 x 337 x 190	10
002150382	DT COMPACT 4.185 T/T PT100	66	3x380-460	38	248 x 337 x 190	10
002150442	DT COMPACT 4.220 T/T PT100	66	3x380-460	44	248 x 337 x 190	10

\* supports PT100 motor temperature protection

## OUTLINE DIMENSIONS

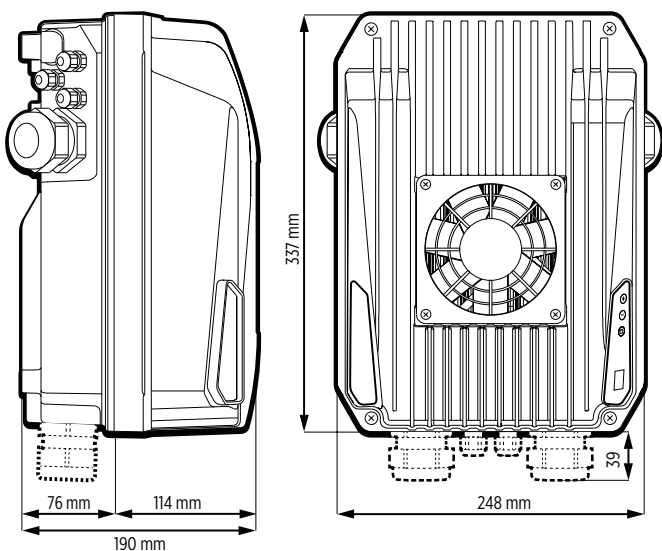

# DRIVE-TECH MINI / DRIVE-TECH COMPACT SPECIFICATION

Mains Connection	Input voltage	1ph 220-240 V; 3ph 380-460 V		
	Input frequency	50-60 Hz (+/- 2%)		
	Displacement power factor (cosphi) near unity	> 0.98		
Motor controls	Control methods	V/F and SVC (Sensorless Vector Control)		
	Control type	PWM (pulse width modulation)		
	Frequency Setting Resolution	Digital Reference: 0.01 Hz		
	Frequency Accuracy	Digital: 0.01 % of Max. Output Frequency		
	V/F Control Curve	Adjustable V/F curve		
	Maximum Output Frequency	1ph 220-240 V models: 300 Hz; 3ph 380- 460VAC models: 300 Hz		
	Overload Capacity	110% of VFD rated current for 1 minute during every 5 minutes of operation		
	Operation Method	Keypad / Terminals / RS-485 Modbus Communication / Bluetooth Mobile App control		
	Analog Input	4 Analog Inputs (2x 0- 10VDC) (2x 4- 20mA)		
By Digital Inputs	Start Signal	Forward, Reverse		
	Stop Signal	Motor ramp down		
	Digital Input	4 programmable digital inputs (Normally Open / Normally Closed), motor run, motor stop		
	Fault Reset	Resets VFD faults via keypad, digital input or communication. Some critical faults can only be reset by cycling the VFD power.		
Outputs	2x Multi-Function Outputs	2 programmable digital outputs (NO, NC), motor run signal, alarm signal		
	RS 485 Serial Port	Output Frequency, Output Current, Output Voltage, Output kW, DC Link Voltage		
Protection	General Operation Functions	Frequency Limit, Jump Frequencies, 2nd ACC/DEC, Auto Restart, Auto-Tuning, PID w/sleep, Temperature Foldback, Run Delay, Minimum Run Timer, PM Motor Control and Auto-Tuning		
	Pump Operation Functions/Protections	Sleep Mode, Pipe Fill, PID, Overpressure, Dry Run (Underload), HLD (High Load), Broken Pipe, No-Flow Protection		
	VFD Fault Trips	Over Voltage, Low Voltage, Over Current, Overload, Short Circuit, Ground Fault, VFD Overheat, Input Phase Loss, Signal Loss, Hardware Fault, etc.		
	Motor Overload	Adjustable electronic motor overload protection		
	Motor temperature	3-wire PT100 motor temperature protection (on request)		
	Overcurrent	220-240 VAC variable torque: at 110% of VFD rated current 380-460 VAC variable torque: at 110% of VFD rated current		
	Overvoltage	380-460 VAC models: at 820VDC DC bus voltage		
	Overtemperature	Built-in IGBT and capacitor bank temperature sensors		
	VFD Alarm	Stall Prevention at ACC and DEC, Overload, Thermal Sensor Fault, Capacitors High Temperature, Signal Loss, Overpressure, Underload, High Load, etc.		
	Keypad Display	Operation Information	Output Frequency, Output Current, Output Voltage, Frequency Reference, Operating Speed, DC Voltage, kWattmeter, Run-time, Last Trip Time, Pressure, etc.	
Fault		Provides 6 fault records and logs 30 faults		
Environment	Operating Temperature	-10 °C - 40 °C (14 °F - 104 °F)		
	Storage temperature	-10 °C - 60 °C (14 °F - 140 °F)		
	Ambient Humidity	up to 95 % RH. (non-condensing)		
	Altitude	Normal up to (1000 m), -1% derating every 100 m		
	Vibration and Impact	Complies with EN 60068-2-6:2008 and EN60068-2-27:2009 and EN60068-2-64:2008		
	Enclosure Ratings	IP66		
Max. Input efficiency (>=X%)	Drive model	Drive-Tech MINI	Drive-Tech COMPACT	
	Input voltage	220-240 AC	95	95
		380-460 VAC	96	97
	CE Low Voltage	EN6100-5-1		
	CE EMC	EN61800-3, EN61000-3-12, IEC61000-4-2, IEC61000-4-3, IEC61000-4-4, IEC61000-4-5, IEC61000-4-6, IEC61000-4-8, IEC61000-6-2, IEC61000-6-4		
Other	C-Tick, ROHS			

## DRIVE-TECH

The Drive-Tech series has been designed to optimize, control and protect your pumping system. It can be used with different pump types such as vertical multistage, centrifugal or submersible pumps, operating in many different applications up to 130 kW.

### FEATURES & BENEFITS

#### CONFIGURATION

- Compatible with three-phase induction or permanent magnet motors
- Available in 1-230V IN / 3-230V OUT or 3-400V IN / 3-400V OUT
- Setup and parameter adjustments through multi row display and user interface
- Low harmonic drive design to meet EN61000-3-12
- Integrated Input filter for use in first environment C1 EN61800-3
- Easy setup with multi level user access and presets
- Programmable Input/Output terminal options
- Robust IP54/55/66 enclosure rating
- Direct wall mount and surface pump mounting



#### APPLICATION-SPECIFIC FEATURES

- Pump specific features including: constant water pressure, flow, level control
- Multi pump operation controlling a second pump at constant speed
- Combo operation connecting up to 8 Drive-Tech MINI units
- Alternating pump mode
- Surface or submersible pump cascading
- Constant speed mode with 2 setpoints

#### OPERATION

- Integrated multi row display allows to select and adjust individual parameter settings
- Fully controllable through Unyconnect mobile app
- Real-time fault logging with date and time stamps
- MPPT control for PV-panel powered solar pumping applications
- Multi power operation allows to use AC and DC supply voltage

#### PROTECTION

- Protection against short circuit, surges, underload, overload, drive overheat, undervoltage, overvoltage, phase loss, phase imbalance, overpressure, sensor fault, etc.
- Pump dry run
- Locked rotor or pump

#### COMMUNICATION

- RS-485 Communications (Modbus) multi pump operation, remote control and monitoring
- Bluetooth connectivity with Unyconnect mobile app
- Bridge mode using 2 smartphones and GSM/Wifi connection for permanent remote control
- Communications for multi-drive operations up to 8 VFDs

# DRIVE-TECH

## MODEL NUMBER DRIVE-TECH

drive model no.	drive type	IP	V <sub>IN</sub> [V]	I <sub>OUT</sub> [A]	dimensions [mm]	weight [kg]	Frame size
002149115	DRIVE-TECH 2.015 M/T 7A - M/M 9A	66	1x220-240	7	180 x 180 x 205	5	1
002149131	DRIVE-TECH 2.030 M/T 11A - M/M9A	66	1x220-240	11	180 x 180 x 205	5	1
002149185	DRIVE-TECH 4.185 T/T 38A	54	3x380-460	38	410 x 680 x 260	40	3
002149220	DRIVE-TECH 4.220 T/T 48A	54	3x380-460	48	410 x 680 x 260	40	3
002149300	DRIVE-TECH 4.300 T/T 65A	54	3x380-460	65	410 x 680 x 260	40	3
002149370	DRIVE-TECH 4.370 T/T 75A	54	3x380-460	75	410 x 680 x 260	40	3
002149450	DRIVE-TECH 4.450 T/T 85A	54	3x380-460	85	410 x 680 x 260	40	3
002149550	DRIVE-TECH 4.550 T/T 118A	54	3x380-460	118	490 x 880 x 380	80	4
002149750	DRIVE-TECH 4.750 T/T 158A	54	3x380-460	158	490 x 880 x 380	80	4
002149900	DRIVE-TECH 4.900 T/T 185A	54	3x380-460	185	490 x 880 x 380	80	4
002151100	DRIVE-TECH 4.1100 T/T 215A	54	3x380-460	215	490 x 880 x 380	80	4
002151320	DRIVE-TECH 4.1320 T/T 268A	54	3x380-460	268	490 x 880 x 380	80	4

## OUTLINE DIMENSIONS

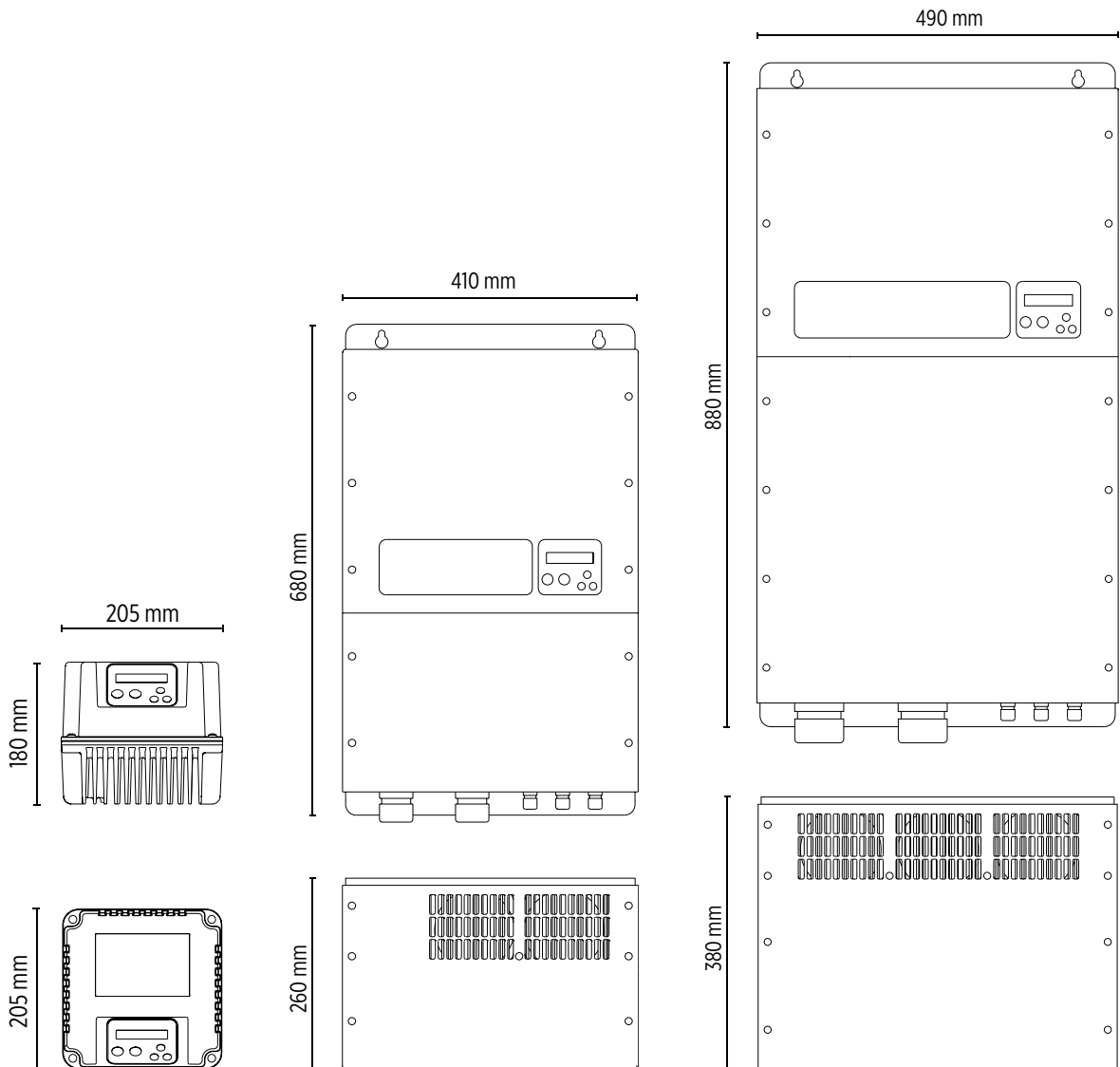

# DRIVE-TECH



DrivE-Tech  
Frame 1



DrivE-Tech  
Frame 3



DrivE-Tech  
Frame 4

# DRIVE-TECH SPECIFICATION

Mains Connection	Input voltage	1ph 220-240 V; 3ph 380-460 V	
	Input frequency	50-60 Hz (+/- 2%)	
	Displacement power factor (cosphi) near unity	> 0.98	
Motor controls	Control methods	V/F and SVC (Sensorless Vector Control)	
	Control type	PWM (pulse width modulation)	
	Frequency Setting Resolution	Digital Reference: 0.01 Hz	
	Frequency Accuracy	Digital: 0.01 % of Max. Output Frequency	
	V/F Control Curve	Adjustable V/F curve	
	Maximum Output Frequency	1ph 220-240 V models: 300 Hz; 3ph 380- 460VAC models: 300 Hz	
	Overload Capacity	110% of VFD rated current for 1 minute during every 5 minutes of operation	
	Operation Method	Keypad / Terminals / RS-485 Modbus Communication / Bluetooth Mobile App control	
	Analog Input	4 Analog Inputs (2x 0- 10VDC) (2x 4- 20mA)	
Protection	By Digital Inputs	Start Signal	Forward, Reverse
		Stop Signal	Motor ramp down
		Digital Input	4 programmable digital inputs (Normally Open / Normally Closed), motor run, motor stop
		Fault Reset	Resets VFD faults via keypad, digital input or communication. Some critical faults can only be reset by cycling the VFD power.
		Safety Inputs	SCM and STO terminals for safety circuit wiring
	Outputs	2x Multi-Function Outputs	2 programmable digital outputs (NO, NC), motor run signal, alarm signal Status Relay (Motor running) / Alarm Relay (Fault)
		Digital Output	2x Digital Relay Output (NO, NC) D.O.L. pump 1 / D.O.L. pump 2
		RS 485 Serial Port	Output Frequency, Output Current, Output Voltage, Output kW, DC Link Voltage
	General Operation Functions	Frequency Limit, Jump Frequencies, 2nd ACC/DEC, Auto Restart, Auto-Tuning, PID w/sleep, Temperature Foldback, Run Delay, Minimum Run Timer, PM Motor Control and Auto-Tuning	
	Pump Operation Functions/Protections	Sleep Mode, Pipe Fill, PID, Overpressure, Dry Run (Underload), HLD (High Load), Broken Pipe, No-Flow Protection	
	VFD Fault Trips	Over Voltage, Low Voltage, Over Current, Overload, Short Circuit, Ground Fault, VFD Overheat, Input Phase Loss, Signal Loss, Hardware Fault, etc.	
	Motor Overload	Adjustable electronic motor overload protection	
Overcurrent	220-240 VAC variable torque: at 110% of VFD rated current 380-460 VAC variable torque: at 110% of VFD rated current		
Overvoltage	380-460 VAC models: at 820VDC DC bus voltage		
Overtemperature	Built-in IGBT and capacitor bank temperature sensors		
Restart After IPF	Adjustable power loss duration up to 20 sec. Leakage current is greater than 50 % of rated current of the drive.		
VFD Alarm	Stall Prevention at ACC and DEC, Overload, Thermal Sensor Fault, Capacitors High Temperature, Signal Loss, Overpressure, Underload, High Load, etc.		
Keypad Display	Operation Information	Output Frequency, Output Current, Output Voltage, Frequency Reference, Operating Speed, DC Voltage, kWattmeter, Run-time, Last Trip Time, Pressure, etc.	
	Fault	Provides active fault/alarm	
Environment	Operating Temperature	-10 °C - 40 °C (14 °F - 104 °F)	
	Storage temperature	-10 °C - 60 °C (14 °F - 140 °F)	
	Ambient Humidity	up to 95 % RH. (non-condensing)	
	Altitude	Normal up to (1000 m), -1% derating every 100 m	
	Vibration and Impact	Comply with EN 60068-2-6:2008, EN60068-2-27:2009 and EN60068-2-64:2008	
	Enclosure Ratings	IP54, IP55, IP66	
Input efficiency (>=X%)	Drive model	Drive-Tech 2.015 - 2.030 / 4.185 - 4.1320	
	Input voltage	220-240 AC	94
		380-460 VAC	97
	CE Low Voltage	EN6100-5-1	
	CE EMC	EN61800-3, EN61000-3-12, IEC61000-4-2, IEC61000-4-3, IEC61000-4-4, IEC61000-4-5, IEC61000-4-6, IEC61000-4-8, IEC61000-6-2, IEC61000-6-4	
	Other	C-Tick, ROHS	

# VARIABLE FREQUENCY SOLAR DRIVES

## DRIVE-TECH SOLAR MP / DRIVE-TECH MINI SOLAR MP / DRIVE-TECH COMPACT SOLAR MP

Specific Drive-Tech, Drive-Tech MINI and Drive-Tech COMPACT variable frequency drives are available for use in solar powered water pumping applications. These drive models can be directly supplied by a VDC solar array without the need of additional equipment and offer the same features as AC grid supplied models. An advanced MPPT algorithm offers best performance during times with less sunlight available, increases water output and ensures a reliable and steady pump operation.



**Drive-Tech MINI Solar MP**

IP66 wall mounted /  
Pump mounted solar  
drive



**Drive-Tech COMPACT  
Solar MP**

IP66 wall mounted /  
Pump mounted solar  
drive



**Drive-Tech Solar MP**

IP65/54 wall mounted  
/ Pump mounted solar  
drive

PV Solar Supply [VDC]	AC Grid Supply [VAC]	Input f [Hz]	Max V <sub>OUT</sub> [VAC]	DTm Solar MP	DTC Solar MP	DT Solar MP
90-400 (650)	1- 90-265	50/60	3x 250	0,55-2,2 kW	(2,2-4,0 kW)	-
320-850	3- 190-520	50/60	(3x250) 3x400	-	4,0-22 kW	(4,0) - 130 kW



# VARIABLE FREQUENCY SOLAR DRIVES

## DRIVE-TECH SOLAR MP / DRIVE-TECH MINI SOLAR MP / DRIVE-TECH COMPACT SOLAR MP

### FEATURES & BENEFITS

#### CONFIGURATION

- Compatible with three-phase induction or permanent magnet motors
- Available in 1-230V IN / 3-230V OUT or 3-400V IN / 3-400V OUT
- Direct VDC supply from PV Solar array
- Optional integrated Plug-In output filter card for Drive-Tech COMPACT
- Low harmonic drive design to meet EN61000-3-12
- Integrated Input filter for use in first environment C1 EN61800-3
- Easy setup with multi level user access and presets
- Programmable Input/Output terminal options
- Outdoor rated IP66 enclosure for use in harsh environments
- Direct wall mount and surface pump mounting



Drive-Tech MINI Solar MP



Drive-Tech COMPACT Solar MP



Drive-Tech Solar MP

#### SPECIFIC DRIVE-TECH MINI SOLAR FEATURES

- Integrated VDC Voltage Boost reduces number of required solar panels significantly
- Integrated multi row OLED display showing alarms, pump speed, set point and more

#### SPECIFIC DRIVE-TECH COMPACT SOLAR FEATURES

- Optional available integrated Plug-In output filter card for extensive motor cable length
- Integrated multi row OLED display showing alarms, pump speed, set point and more

#### APPLICATION-SPECIFIC FEATURES

- Pump specific features including: constant water pressure, flow, level control
- Multi pump mode
- Alternating pumps
- Constant speed mode with 2 setpoints

#### OPERATION

- Integrated digital display and user interface with full control of drive settings
- Fully controllable through Unyconnect mobile app
- Real-time fault logging with date and time stamps
- MPPT control for PV-panel powered solar pumping applications
- Multi power operation allows to use AC and DC supply voltage

#### PROTECTION

- Protection against short circuit, surges, underload, overload, drive overheat, undervoltage, overvoltage, phase loss, phase imbalance, overpressure, sensor fault, etc.

#### COMMUNICATION

- RS-485 Communications (Modbus) multi pump operation, remote control and monitoring
- Bluetooth connectivity with Unyconnect mobile app
- Bridge mode using 2 smartphones and GSM/Wifi connection for permanent remote control
- Communications for multi-drive operations up to 8 VFDs

\* Full control of drive settings through user interface only on Drive-Tech Solar

# VARIABLE FREQUENCY SOLAR DRIVES

## DRIVE-TECH SOLAR MP / DRIVE-TECH MINI SOLAR MP / DRIVE-TECH COMPACT SOLAR MP

### MODEL NUMBERS VARIABLE FREQUENCY SOLAR DRIVES

Drive PN	drive type	IP	VAC <sub>IN</sub> [V]	Max VDC <sub>IN</sub> [V]	I out [A]	dimensions [mm]	weight [kg]
314000165	DT MINI Solar 2.005 MP 3A	66	1x220-240	400	3		2.5
314000166	DT MINI Solar 2.011 MP 5A	66	1x220-240	400	5	150 x 211 x 130	2.5
314000167	DT MINI Solar 2.015 MP 7,5A	66	1x220-240	400	7.5	150 x 211 x 130	2.5
314000210	DT COMPACT Solar 2.022 MP 9,5A	66	1x220-240	650	9.5	248 x 337 x 190	10
314000211	DT COMPACT Solar 2.030 MP 12,5A	66	1x220-240	650	12.5	248 x 337 x 190	10
314000212	DT COMPACT Solar 2.040 MP 18,5A	66	1x220-240	650	18.5	248 x 337 x 190	10
002150141	DT COMPACT Solar 4.055 MP 14A	66	3x380-460	850	14	248 x 337 x 190	10
002150181	DT COMPACT Solar 4.075 MP 18A	66	3x380-460	850	18	248 x 337 x 190	10
002150251	DT COMPACT Solar 4.110 MP 25A	66	3x380-460	850	25	248 x 337 x 190	10
002150301	DT COMPACT Solar 4.150 MP 30A	66	3x380-460	850	30	248 x 337 x 190	10
002150381	DT COMPACT Solar 4.185 MP 38A	66	3x380-460	850	38	248 x 337 x 190	10
002150441	DT COMPACT Solar 4.220 MP 44A	66	3x380-460	850	44	248 x 337 x 190	10
314000161	DT Solar 3.030 MP 14A	66	3x380-460	850	14	260 x 260 x 180	9
002149A08	DT Solar 4.220 MP 48A	54	3x380-460	850	48	410 x 680 x 260	40
002149A09	DT Solar 4.300 MP 65A	54	3x380-460	850	65	410 x 680 x 260	40
002149A10	DT Solar 4.370 MP 75A	54	3x380-460	850	75	410 x 680 x 260	40
002149A11	DT Solar 4.450 MP 85A	54	3x380-460	850	85	410 x 680 x 260	40
002149A12	DT Solar 4.550 MP 118A	54	3x380-460	850	118	490 x 880 x 380	80
002149A13	DT Solar 4.750 MP 158A	54	3x380-460	850	158	490 x 880 x 380	80
002149A14	DT Solar 4.900 MP 185A	54	3x380-460	850	185	490 x 880 x 380	80
002149A15	DT Solar 4.1100 MP 215A	54	3x380-460	850	215	490 x 880 x 380	80
002149A16	DT Solar 4.1320 MP 268A	54	3x380-460	850	268	490 x 880 x 380	80

\* Drive-Tech Solar 4.220 - 4.1320 on request (non-stock item)

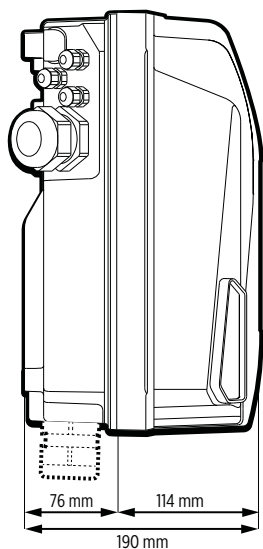

Drive-Tech COMPACT Solar MP

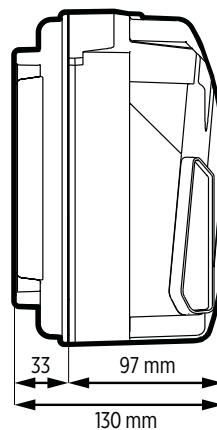
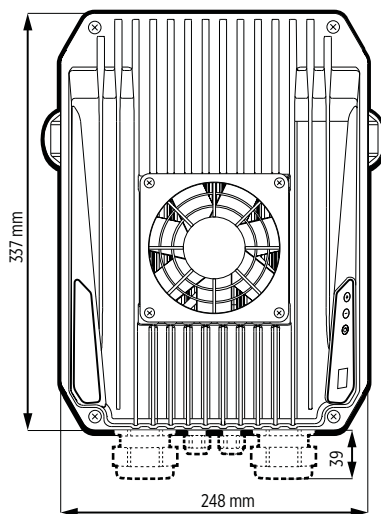

Drive-Tech MINI Solar MP

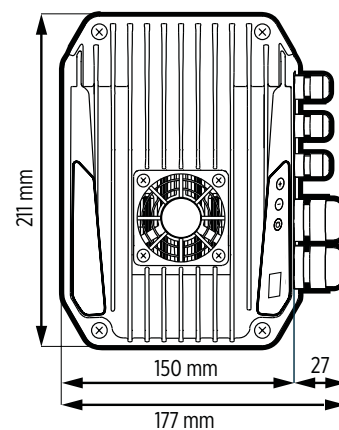

# VARIABLE FREQUENCY SOLAR DRIVES

## DRIVE-TECH SOLAR MP / DRIVE-TECH MINI SOLAR MP / DRIVE-TECH COMPACT SOLAR MP

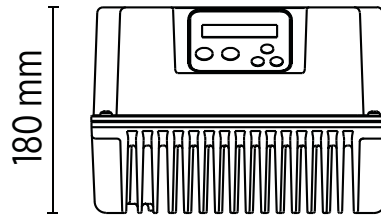
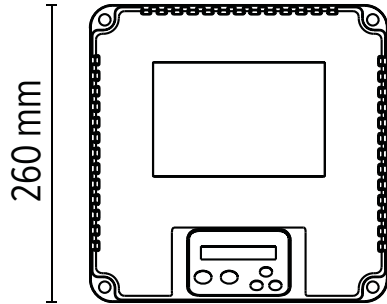

Drive-Tech Solar MP

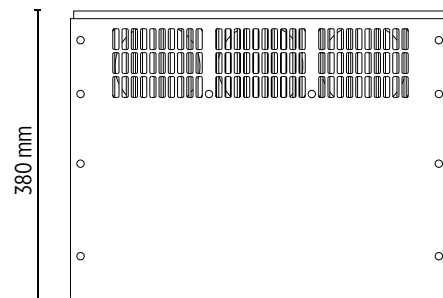
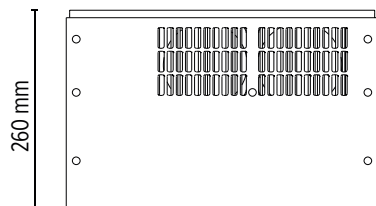
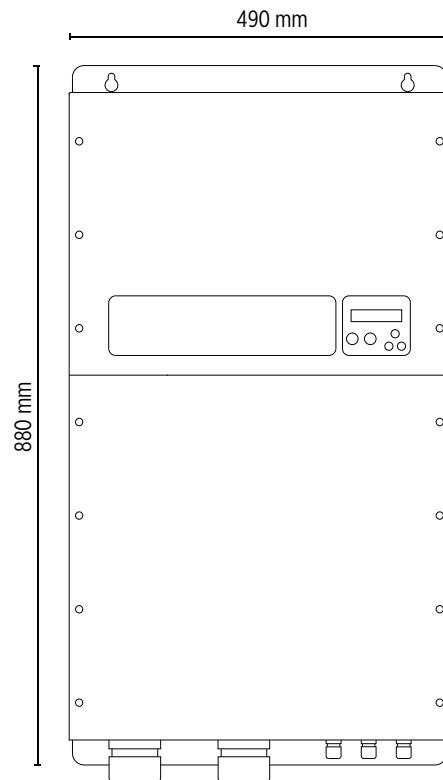
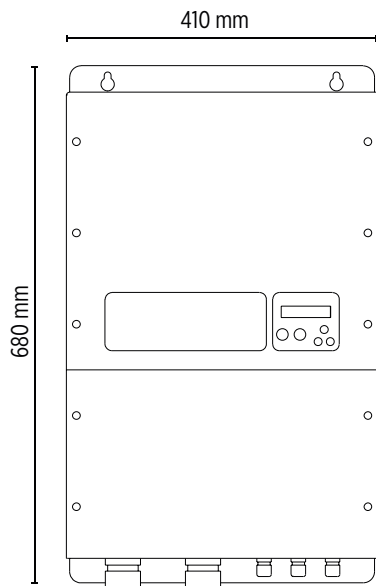

Drive-Tech

# VARIABLE FREQUENCY DRIVE SELECTION GUIDE

To ensure best performance and a reliable pump operation the variable frequency drive must be correctly sized and selected. This selection guide will support you in selecting the right VFD for your pumping application.

## SIZING A VFD

To produce the required speed and torque of a motor, the VFD must provide the motor with sufficient voltage [V] at enough current [A].

Where will the drive be installed?  
Check with customer / installer

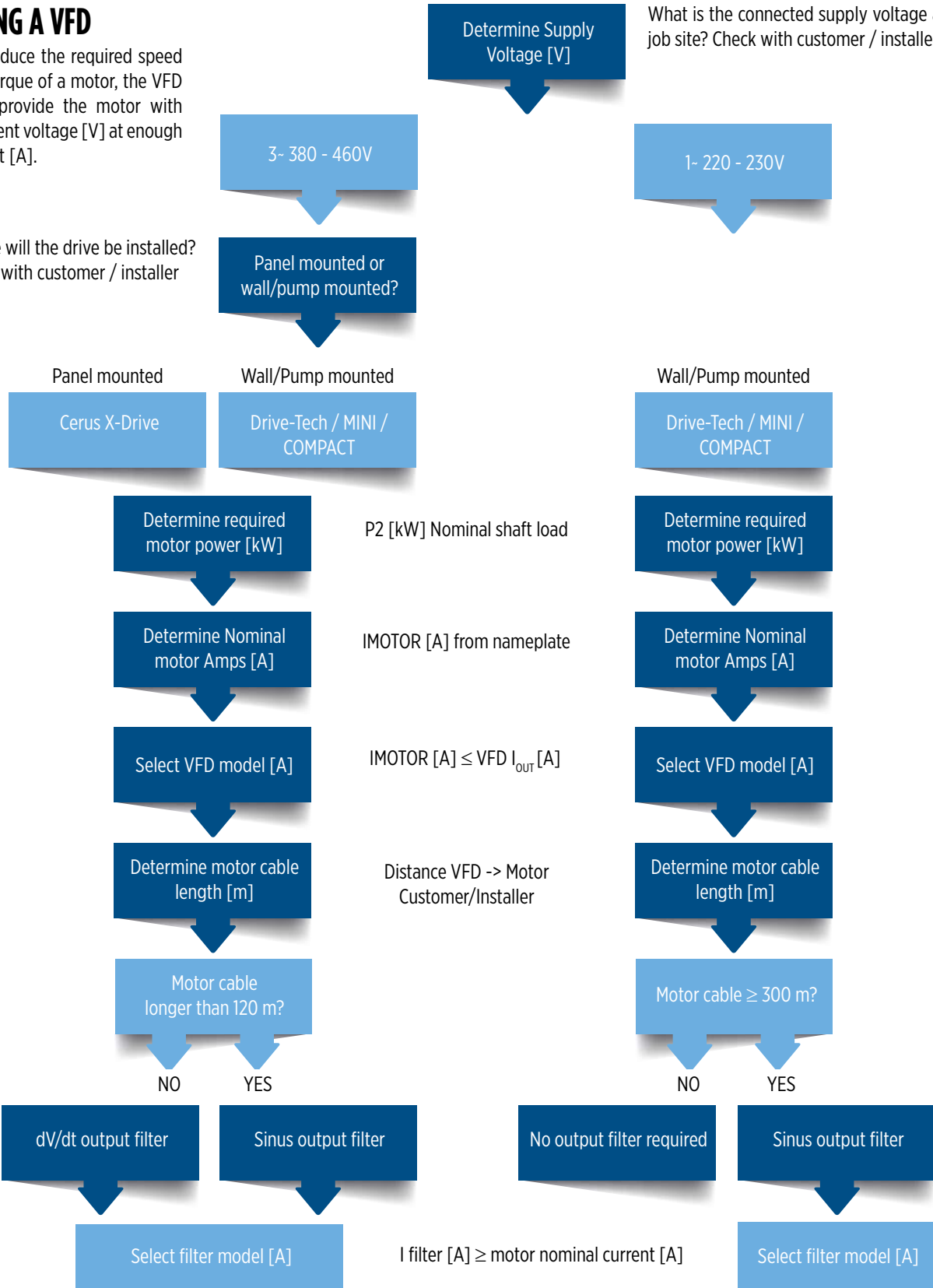

# INPUT FILTER

- A VFD input filter or EMI/EMC filter reduces the transfer of electromagnetic noise between the drive and mains power supply. Input filters can be used to improve electromagnetic compatibility in certain environments or if a higher level of filtering is desired.
- Required when using 3x400 V AC induction and permanent magnet motors with VFD

## FEATURES & BENEFITS

- The size of the input filter is selected according to the VFD nominal input current [A].
- For use with 3ph input VFD (e.g. 3x400V)
- Improves EMC and reduces emissions on mains supply.

filter model no.	Type	IP	V <sub>NOMINAL</sub> [V]	I <sub>NOMINAL</sub> [A]	dimensions [mm]	weight [kg]
On Request	EMI/EMC	20	380 - 520	20	58 x 150 x 58	1
On Request	EMI/EMC	20	380 - 520	50	85 x 217 x 80	1.5
On Request	EMI/EMC	20	380 - 520	80	95 x 256 x 90	2.5

B84143A0010R106, B84143A0020R106 (10 A, 20 A)

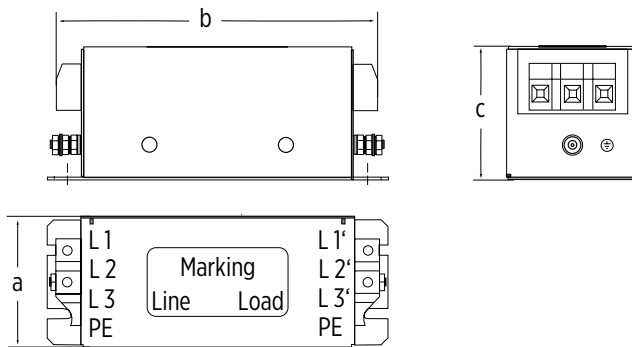

B84143A0050R106, B84143A0065R106 (50 A, 65 A)

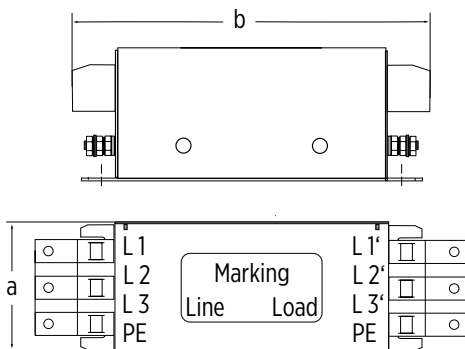

B84143A0080R106 (80 A)

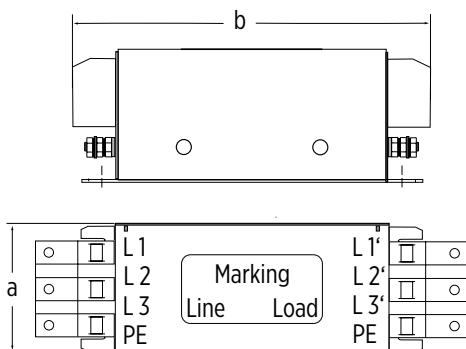

input filter REV.00 08-2023

## OUTPUT FILTER

- A VFD output filter or load reactor acts as an additional impedance between VFD and motor. It protects the motor winding and reduces the voltage stress by decreasing the voltage rise time (dV/dt) and tapering the output voltage waveform of the VFD. Optimizing the VFD output voltage waveform into a more suitable profile prevents the risk of high voltage reflexion caused by long motor cable length.
- Required when using 3x400 V AC induction and permanent magnet motors with VFD
- Use dV/dt output filter for motor cable lengths of 4 - 120 m.
- Use Sinus output filter for motor cable lengths greater than 120 m.
- The size of a dV/dt or Sinus filter must be selected according to the nominal motor current [A]

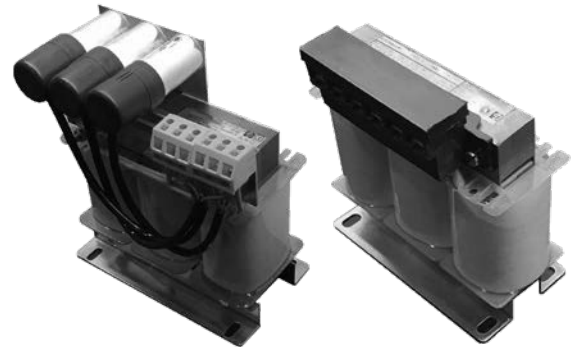

Sinus output filter

dV/dt output filter

### FEATURES & BENEFITS

- For use with 3x400 V AC induction and permanent magnet motors
- Protects motor winding against high voltage peaks and increases lifetime
- Reduces motor noise
- Improves EMC and reduces emissions

## DV/DT OUTPUT FILTER

### MODEL NO. DV/DT OUTPUT FILTER IP00

filter model no.	Type	IP	V <sub>NOMINAL</sub> [V]	I <sub>NOMINAL</sub> [A]	fs [kHz]	Dimensions a x b x c [mm]	Mounting	weight [kg]
*002352414	dV/dt	00	380 - 460	14	4	120 x 67 x 115	wall / floor	2.7
*002352432	dV/dt	00	380 - 460	32	4	140 x 75 x 150	wall / floor	3.5
*002352490	dV/dt	00	380 - 460	90	4	180 x 120 x 200	wall / floor	8
314005301	dV/dt	00	380 - 460	38	2-6	155 x 80 x 165	wall / floor	3.5
314005302	dV/dt	00	380 - 460	105	2-6	230 x 145 x 210	wall / floor	11.5
314005303	dV/dt	00	380 - 460	140	2-6	230 x 145 x 210	wall / floor	12
314005304	dV/dt	00	380 - 460	150	2-6	230 x 145 x 210	wall / floor	12
314005305	dV/dt	00	380 - 460	205	2-6	230 x 155 x 210	wall / floor	13
308005306	dV/dt	00	380 - 460	310	2-6	265 x 200 x 235	wall / floor	28
314005307	dV/dt	00	380 - 460	460	2-6	300 x 200 x 280	wall / floor	30
314005308	dV/dt	00	380 - 460	590	2-6	300 x 240 x 285	floor	40

\* Mountable filter (optional filter box available)

### MODEL NO. DV/DT OUTPUT FILTER IP54

filter model no.	type	IP	V <sub>NOMINAL</sub> [V]	I <sub>NOMINAL</sub> [A]	fs [kHz]	Dimensions a x b x c [mm]	Mounting	weight [kg]
*002352414	dV/dt	54	380 - 460	14	4	164 x 196 x 141	wall	4.2
*002352432	dV/dt	54	380 - 460	32	4	164 x 196 x 141	wall	5
*002352490	dV/dt	54	380 - 460	45	4	264 x 339 x 211	wall	11.5
314005309	dV/dt	54	380 - 460	62	2-6	400 x 250 x 500	wall	18
314005310	dV/dt	54	380 - 460	88	2-6	400 x 250 x 500	wall	21
314005311	dV/dt	54	380 - 460	140	2-6	400 x 250 x 500	wall	25
314005312	dV/dt	54	380 - 460	205	2-6	400 x 500 x 250	wall	29
314005313	dV/dt	54	380 - 460	310	2-6	500 x 500 x 250	floor	40

\* Mountable filter (optional filter box available)

## FILTER BOX

filter type	[A]	part no.	IP23		IP54		
			Box Size		Box Size		
			1	2	1	2	3
dV/dt	14	002352414	002150FB0	002150FB1	002150FB2	002150FB3	002150FB4
	32	002352432	✓	✓	50% derating	✓	✓
	90	002352490	x	✓	x	50% derating	✓

## PLUG-IN OUTPUT FILTER CARD

drive type	Kit PN
<b>Drive-Tech COMPACT</b> DTC plug-In dV/dt filter card 32A DTC 4.055 - 4.150	002150FC0 

# DV/DT OUTPUT FILTER

## PICTURES AND OUTLINES



dV/dt output filter



filter connection plan

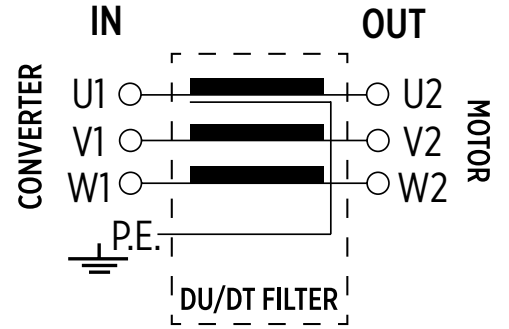

IP54 filter outlines floor mount

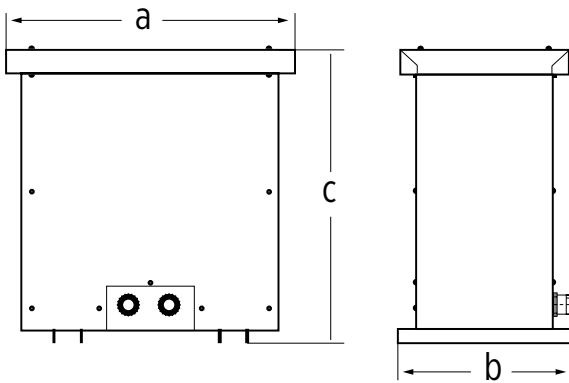

08-2023

IP54 filter outlines wall mount

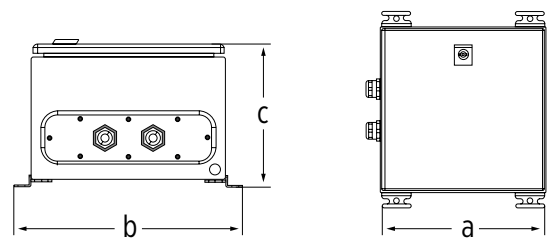

08-2023

IP00 dV/dt filter outlines

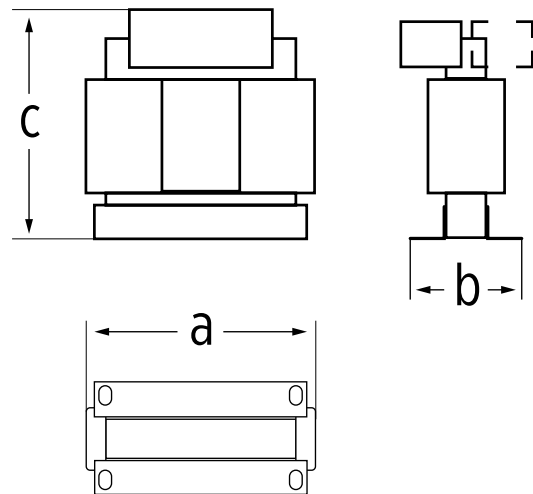

08-2023

# SINUS OUTPUT FILTER

## MODEL NO. SINUS OUTPUT FILTER IP00

filter model no.	type	IP	V <sub>NOMINAL</sub> [V]	I <sub>NOMINAL</sub> [A]	fs [kHz]	Dimensions a x b x c [mm]	Mounting	weight [kg]
*002347013	Sinus	00	380 - 460	14	4	180 x 105 x 210	wall / floor	10
*002347011	Sinus	00	380 - 460	32	4	240 x 115 x 280	wall / floor	17.5
*002347012	Sinus	00	380 - 460	115	4	300 x 150 x 285	floor	42
314005325	Sinus	00	380 - 460	38	≥4	240 x 200 x 270	wall / floor	17
314005326	Sinus	00	380 - 460	105	≥4	360 x 280 x 320	floor	43
314005327	Sinus	00	380 - 460	140	≥4	360 x 280 x 320	floor	55
314005328	Sinus	00	380 - 460	205	≥4	420 x 330 x 380	floor	85
314005329	Sinus	00	380 - 460	261	≥4	420 x 380 x 380	floor	120
314005330	Sinus	00	380 - 460	310	≥4	480 x 500 x 430	floor	120
314005331	Sinus	00	380 - 460	460	≥4	480 x 550 x 430	floor	175
314005332	Sinus	00	380 - 460	590	≥4	480 x 600 x 560	floor	235

\* Mountable filter (optional filter box available)

## MODEL NO. SINUS OUTPUT FILTER IP54

filter model no.	type	IP	V <sub>NOMINAL</sub> [V]	I <sub>NOMINAL</sub> [A]	fs [kHz]	Dimensions a x b x c [mm]	Mounting	weight [kg]
*002347013	Sinus	54	380 - 460	14	4	264 x 339 x 211	wall	13.5
*002347011	Sinus	54	380 - 460	32	4	264 x 339 x 211	wall	21
314005333	Sinus	54	380 - 460	38	≥4	400 x 250 x 500	floor	30
314005334	Sinus	54	380 - 460	105	≥4	600 x 350 x 750	floor	78
314005335	Sinus	54	380 - 460	140	≥4	600 x 350 x 760	floor	85
314005336	Sinus	54	380 - 460	205	≥4	855 x 630 x 670	floor	130
314005337	Sinus	54	380 - 460	261	≥4	1050 x 760 x 750	floor	180
314005338	Sinus	54	380 - 460	310	≥4	1050 x 760 x 750	floor	180

\* Mountable filter (optional filter box available)

## FILTER BOX

filter type	[A]	part no.	IP23		IP54		
			Box Size		Box Size		
			1	2	1	2	3
			002150FB0	002150FB1	002150FB2	002150FB3	002150FB4
Sinus	14	002347013	x	✓	x	✓	✓
	32	002347011	x	✓	x	✓	✓
	115	002347012	x	x	x	x	✓

# SINUS OUTPUT FILTER

## PICTURES AND OUTLINES

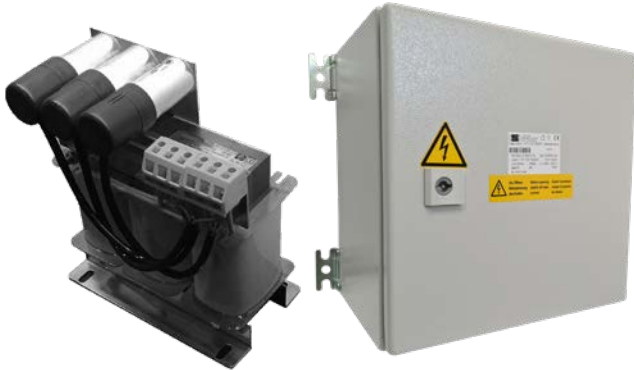

Sinus output filter

filter connection plan

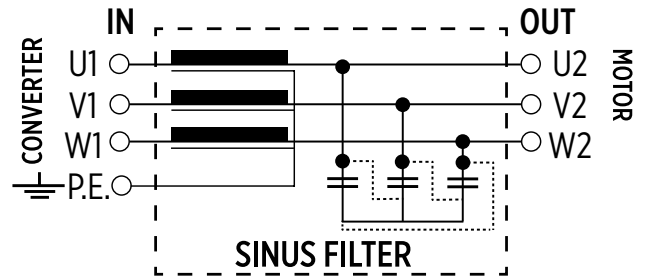

IP54 filter outlines wall mount

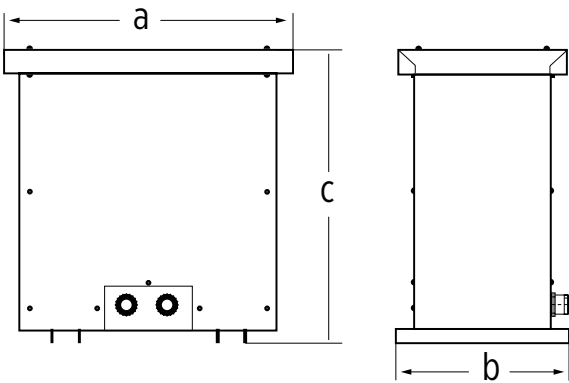

08-2023

IP54 filter outlines wall mount

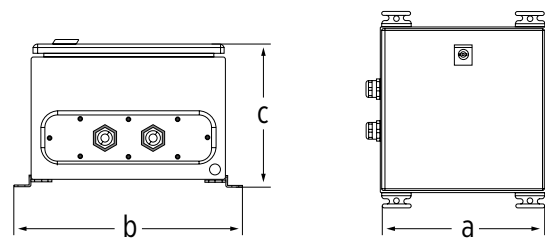

08-2023

IP00 Sinus filter outlines

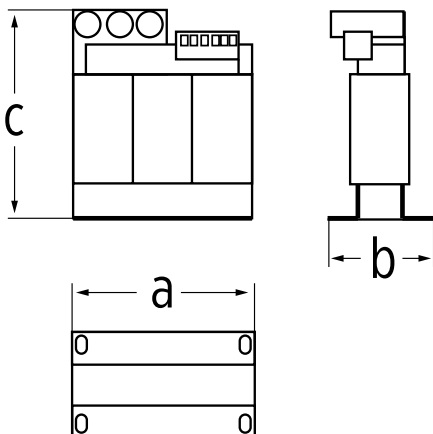

\*For IP54 rating the recommended enclosure size is 20 liter.

# OUTPUT FILTER ACCESSORIES

## FILTER HOUSING

- Optional output filter boxes can be used in combination with dedicated output filter models to increase the IP enclosure rating and protect the output filter when installed outside of a control panel.
- Please refer to the below table to select the correct output filter box. Due to the thermal characteristics and heat dissipation of an output filter it is required to apply a 50% output filter current [A] derating when IP 54 rated filter boxes are used.
- Example: Installing the 32A dV/dt output filter model (002352432) in the IP54 rated filter box (box size 1) will limit the max. output filter current to 50% = 16A max. output filter current.



filter type	[A]	part no.	IP23		IP54		
			Box Size		Box Size		
			1	2	1	2	3
			002150FB0	002150FB1	002150FB2	002150FB3	002150FB4
dV/dt	14	002352414	✓	✓	✓	✓	✓
	32	002352432	✓	✓	50% derating	✓	✓
	90	002352490	x	✓	x	50% derating	✓
Sinus	14	002347013	x	✓	x	✓	✓
	32	002347011	x	✓	x	✓	✓
	115	002347012	x	x	x	x	✓

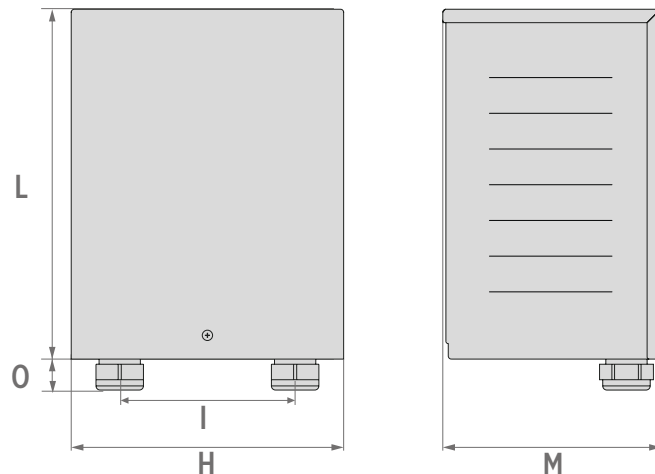

## DIMENSIONS

Box Size	part no.	Dimensions [mm]				
		L	H	M	O	I
1	002150FB0	196	164	141	29	100
1	002150FB2	196	164	141	29	100
2	002150FB1	339	264	211	30	170
2	002150FB3	339	264	211	30	170
3	002150FB4	800	600	400		





## VARIABLE FREQUENCY DRIVE ACCESSORIES

### PRESSURE TRANSDUCER

Transducer part no.	Type	Range	Signal [mA]	Material	
002851075	Pressure sensor without cable	0-10 Bar	4-20	304SS	
002851080	Pressure sensor without cable	0-16 Bar	4-20	304SS	
002851085	Pressure sensor without cable	0-25 Bar	4-20	304SS	
002852211	Pressure sensor with 2m shielded cable	0-16 Bar	4-20	304SS	
002851088	Pressure sensor with 2m shielded cable	0-16 Bar	4-20	316SS	

### MOTOR AND WALL MOUNTING KITS

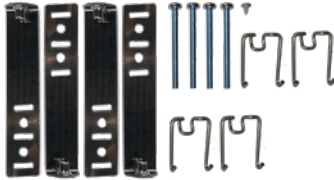
#### DrivE-Tech

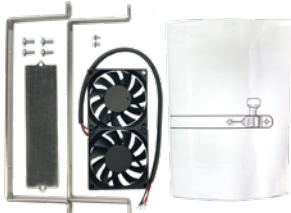
Type	Kit model no.	
Motor Mounting Kit for DrivE-Tech 2.015, 2.030, 4.022, 4.040 <ul style="list-style-type: none"> <li>▪ Screws and connectors</li> <li>▪ Motor mounting frames</li> </ul>	14211110	
Wall installation kit for 2.015, 2.030, 4.022, 4.040 <ul style="list-style-type: none"> <li>▪ Fan with protective grid</li> <li>▪ Screws</li> <li>▪ Wall mounting plate</li> </ul>	14211121	
Wall installation kit for DT 4.055 - 4.150 <ul style="list-style-type: none"> <li>▪ Fan 2x</li> <li>▪ Screws</li> <li>▪ Wall mounting frames</li> <li>▪ cover plate</li> </ul>	14211030	

#### DrivE-Tech COMPACT

Type	Kit model no.	
Wall installation kit for DT Compact 2.022 - 4.221 <ul style="list-style-type: none"> <li>▪ Screws and connectors</li> <li>▪ Wall mounting plate</li> </ul>	002150WK0	

## VARIABLE FREQUENCY DRIVE ACCESSORIES

### PLUG-IN OUTPUT FILTER CARD

#### Drive-Tech COMPACT

Kit part no.	Type	
002150FC0	DTC plug-In dV/dt filter card 32A DTC 4.055 - 4.150	



### QUICK SETUP ACCESSORY KIT

#### Drive-Tech MINI

part no.	Type	
002150AP0	Wall mounting plate 1.50 m SCHUKO supply cable FASTON cable connectors	





### DRIVE-TECH ACCESSORIES

#### Drive-Tech

part no.	Type	
308216110	<p>KIT IOT WIFI DRIVE-TECH</p> <ul style="list-style-type: none"> <li>Remote control / monitoring via WIFI</li> <li>32 GB SD storage card</li> <li>High-performance antenna</li> </ul>	
308206110	<p>KIT IOT GSM DRIVE-TECH</p> <ul style="list-style-type: none"> <li>Remote control / monitoring vis GSM</li> <li>32 GB SD storage card</li> <li>High-performance antenna</li> <li>SIM card <u>not</u> included</li> </ul>	

## X-DRIVE ACCESSORIES

### Cerus X-Drive

part no.	Type	
10000004840	Bluetooth communications card for X-Drive	
CXD-KPD	X-Drive replacement keypad	
CMC-EIP01 CMC-EIP02	Modbus TCP / Ethernet Card	
MKC-KPPK	X-Drive control panel door mounting kit	

## BROCHURES / CATALOGS



Download our Quick set-up guide from our website [franklinwater.eu](http://franklinwater.eu) to perform the installation step by step via mobile App:

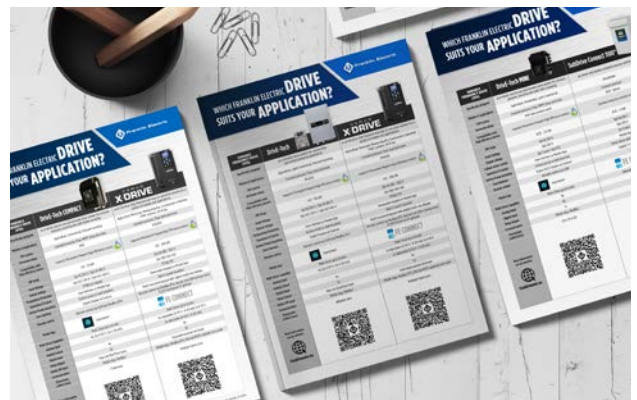

Download our comparison sheets from our website [franklinwater.eu](http://franklinwater.eu)



Technical Bulletin FE CONNECT One-to-One™



FE CONNECT One-to-One™

## SEE ALSO THESE PRODUCT CATALOGS WITH VFDS:



High Efficiency System



Boosting systems



Vertical Multistage pumps with Drive-Tech Variable Frequency drives



Horizontal Multistage pumps with Drive-Tech Variable Frequency drives

## RELATED VIDEOS



One-to-One™ Remote control feature



permanent magnet technology



FE CONNECT



Boosting systems



## CATALOG REVISION CHANGES NOTICE

Rev. No.	Changes	Page
01	XDrive K version (drive incl. Bluetooth plug-in-card) added, XDrive accessories added	7, 8, 32
02	mounting options added	26, 28
	table data (I Nominal) of dV/dt filter adjusted	14
03	new picture Drive-Tech framesize 1	4, 16, 18
	model no., enclosure rating and dimensions of Drive-Tech framesize 1 adjusted	17, 19
	model no., current, dimensions and weight of output filters adjusted	26, 28
	motor and wall mounting kits adjusted	31
04	Bluetooth communication card for X-Drive added	32
	Accessories added	32 - 34
	Drive-Tech Solar models added	22
	Output filter boxes added	27, 29, 31
05	update picture wall mounting kit 14211110	32
	model no. Drive-Tech accessories adjusted	33
06	update picture of wall installation kit for 14211121	32
	One-to-One™ Remote control feature added	6
07	Pressure transducer adjusted	32
	output filters and output filter boxes adjusted	27, 29, 31



## Franklin Electric

Franklin Electric Europa GmbH  
Rudolf-Diesel-Str. 20 - 54516 Wittlich  
GERMANY  
Phone: +49 (0) 6571 - 105-0  
Fax: +49 (0) 6571 - 105-510  
Email: info@franklin-electric.de

Franklin Electric S.r.l.  
Via Asolo, 7 - 36031 Dueville (Vicenza)  
ITALY  
Phone: +39 0444 361114  
Fax: +39 0444 365247  
Email: sales.it@fele.com



franklinwater.eu



10000014015 EN REV.07\_12-2025

Single member - Company subject to the control and coordination of Franklin Electric Co., Inc.  
Franklin Electric reserves the right to amend specification without prior notice.